



PEGASUS®

MD Device

**Models: MD441
MD641
MD643**

Thank you for purchasing Pegasus' labor saving device.

Study this manual very carefully before beginning any of the procedures and then use the device correctly and safely.

Keep this manual in a convenient place for quick reference when needed.

Elastic lace feeder

INSTRUCTIONS

9A2853E

CONTENTS

1. Introduction	1
2. Indications of dangers, warnings & cautions	1-2
3. Safety precautions	2-3
4. Notes for each procedure	3-4
Applications and performance	5
System construction	7
Installing each component	8-10
Description of MD power box	11
Connecting cords	12
Replacing the fuse for the power box	13
Connecting air lines and adjusting the filter regulator	14
Inserting elastic lace	15
Adjusting the guides according to the width of the elastic lace	16
Functions of the machine treadle/external switches	17
Adjusting the sensitivity of sensor	18
Description of MD console box	19
Entering the sewing data	20-28
1. Before entry	20
2. Data entered at the factory	21
3. Function selecting mode	21-27
4. Changing PGM (items)	28
Sewing	29-35
1. Programming patterns	29
2. Programming steps	30
3. Finishing the program of step	31
4. Programming the AT (automatic tape cutter)	32
5. To continue to sew pattern after pattern	33
6. To complete sewing when the current pattern is finished	33
7. Teaching	34
8. Sewing	35
Testing mode	36-40
Error message	40

Be sure to study very carefully **for safety.**

1. Introduction

- This manual describes the instructions for using this device safely.
- Study this manual very carefully and understand fully how to operate, check, adjust and maintain the labor saving device before beginning any of the procedures.
- You always perform operations close to moving parts such as needles when using industrial sewing machines. Therefore you have to keep in mind you could easily touch them. To prevent accidents, it is essential that you use the safe products supplied by Pegasus correctly.
All the people who will use sewing machines must study this manual and the instruction manual for sewing machines very carefully and then take necessary safety measures before beginning any of the procedures.

2. Indications of dangers, warnings and cautions



To prevent accidents, indications (symbols and/or signs) which show the degree of danger are used on our products and in this manual. Study the contents very carefully and follow the instructions.

Indication labels should be found easily.









Attach new labels when they are stained or removed.

Contact our sales office when new labels are needed.

Symbols, signs and/or signal words which attract users' attention

 DANGER	Indicates an immediate hazard to life or limb.
 WARNING	Indicates a potential hazard to life or limb.
 CAUTION	Indicates a possible mistake that could result in injury or damage.

Symbols and messages

	Be sure to follow the instructions when you operate the machine and/or labor saving device.
	If you use the machine and/or labor saving device incorrectly, you may get an electrical shock.
	If you use the machine and/or labor saving device incorrectly, your hands and/or fingers may be injured.
	If you use the machine and/or labor saving device incorrectly, you may cause fire.
	Never do this.
	Unplug the machine or shut off the power when checking, adjusting and/or repairing the machine and/or labor saving device, or when lightning may strike.
	Be sure to ground the machine and labor saving device securely.
	If you use the machine and/or labor saving device incorrectly, your fingers and/or hands may be caught in them or it, causing trouble.
	Indicates a danger of burn injury due to high temperature.

3. Safety precautions

① Applications, purpose

The labor saving device is designed to increase quality and productivity according to you needs. Therefore never use the device for the applications which may defeat the above purpose.

② Circumstances

Some circumstances when you are using the labor saving device may affect its life, function, performance, and safety.



For safety, do not use the labor saving device under the circumstances below.

1. Do not use the device near objects which make noise such as a high-frequency welder, etc.
2. Do not use or store the device in the air which has vapor from chemicals, or do not expose the device to chemicals.
3. Do not leave the device outside, in high temperatures or the direct sun.
4. Do not use the device in high humidity or ambient temperatures which may affect them.

5. Do not use the device on the condition that the voltage fluctuation range is more than $\pm 10\%$ of the rated voltage.
6. Do not use the device at the place where the supply voltage specified for the control motor cannot be properly obtained.
7. Do not use the device at the place where the air supply specified for the device cannot be properly obtained.
8. Do not expose the device to the water.

③ Safety measures



(1) Safety precautions when you perform maintenance on the labor saving device.

- When performing maintenance such as when checking, repairing, cleaning the labor saving device, turn off the power, disconnect the power plug from the outlet and press the machine treadle in order to make sure the machine does not run. If you have to perform maintenance on the machine and/or labor saving device with the power on, always be careful because the machine and/or device could start operating unexpectedly. To prevent accidents caused by incorrect operation, you should establish your own procedures for safe operation and follow them.

- Only well-trained people should perform routine daily maintenance and/or repair the machine and/or device.

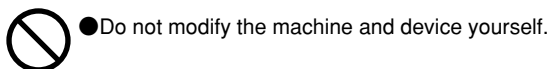

- Do not modify the machine and device yourself.

※ Consult your local Pegasus' sales office or representative for modification.



(2) Before operating the device

- Before operating the device, check the machine head, machine unit and device to make sure they do not have any damage and/or defects.
Repair or replace any defective parts immediately.
- To prevent accidents, always make sure the safety covers and safety guards are properly secured.
Never remove the safety covers and safety guards.



(3) Training

- To prevent accidents, operators and service/maintenance personnel should have proper knowledge and skills for safe operation.
To ensure so, managers must design and conduct training for these people.

4. Notes for each procedure



CAUTION

① Unpacking

The machine and device are packed in boxes (and plastic bags) in the factory before shipment. Unpack the boxes and bags properly and sequentially by following the instructions shown on them.

② Installation, preparation



CAUTION

Connecting the air lines

1. Always turn off the power first and then connect the air lines to the joints. Be sure to connect all the air lines before connecting them to the air source.
2. When connecting the air lines to the joints, be sure to insert the joints to the proper depth of the air lines and fasten securely.
3. Do not allow excessive force to be exerted on the air lines while using the device.
4. Do not bend the air lines too much.
5. If necessary, protect the air lines by positioning them safely and/or using the cover.

6. Do not use staples to secure the air lines. Otherwise it may cause damage.



WARNING

Connecting the cords

1. When connecting the power cord, be sure to turn off the power and disconnect the power plug from the outlet.
2. Check the voltage designation to make sure the power relay cord matches the local supply voltage. The use of wrong cord may cause damage to parts and/or fire.
3. Do not allow excessive force to be exerted on the cords while using the device.
4. Do not bend the cords too much.
5. Confirm that the cord is at least 25mm away from moving part of the machine and/or the device when you connect the cord.
6. If necessary, protect the cords by positioning them safely and/or using the cover.
7. Do not use staples to secure the cords. Otherwise it may cause damage.

Ground

1. Connect each of the ground wires in the sewing machine system to the ground terminal. Do not connect one devices' ground wire to another devices'.
2. Connect the ground wires securely to the indicated ground points on the machine head.





WARNING

③ Before operation

1. Check the cords, connector and air lines to make sure they do not have any damage, disconnections or tangles and then turn on the power.
2. Do not bring your hands and/or any part of your body close to the needle and pulley when turning on the power.
3. Well-trained people who studied this manual and the instruction manual very carefully should use the machine with the labor saving device.
4. Study the contents on "2. Indications of dangers, warnings and cautions" very carefully and then provide users with safety training as required.

WARNING

④ Precautions for work and operation

1.  The area near the presser foot is very dangerous during sewing. Do not bring your hands and/or any part of your body close to the presser foot.
2. To prevent accidents, be careful that any foreign matter such as water, other liquids or metals do not get into the device.
3. Wear clothes that cannot be caught in the machine.
4.  Do not leave tools or other unnecessary objects near the device.
5. To prevent accidents, always make sure the safety cover are properly secured.
6. Drain and clean the filter regulator periodically, if the device is pneumatic. Otherwise drainage will flow into the solenoid valve and/or air cylinder, causing trouble.
7. Always turn off the power before leaving the machine table.
8. If any trouble occurs, stop using the machine and turn off the power. Check, repair and/or perform other necessary procedures immediately.
9.  Pay close attention to the knife edges not to injure your hands and/or fingers.

Battery in the power box

The MD power box is equipped with a battery to keep the sewing data as it is.



If the following happens, the battery may be dead or the power box may be out of order.

Consult your local Pegasus sales office or representative.

- (1) The sewing data which has been entered often changes.
- (2) When the power is turned on, the sewing data is initialized.

CAUTION

⑤ Maintenance, check & repair

1. Well-trained people who studied this instructions very carefully should maintain, check and repair the machine and device.
 2. Perform routine daily maintenance and periodical maintenance by following this instructions.
 3. Use Pegasus' genuine parts when repairing and/or replacing parts.
Pegasus disclaims all responsibility for accidents caused by improper repair/adjustment and/or use of parts which are not genuine.
 4.  Do not modify the device yourself.
Pegasus disclaims all responsibility for accidents caused by modification.
 5. After maintaining, checking, and/or repairing the machine and device, always make sure that any trouble does not occur when the power is turned on.
 6. Before and after operation clean lint and any other foreign from the device not to cause trouble.
 7. Make sure to replace the safety covers when you need to remove them for checking and/or maintenance.
-  To prevent accidents, never put your finger in knives and roller. Be careful that sleeve cannot be caught in the roller.

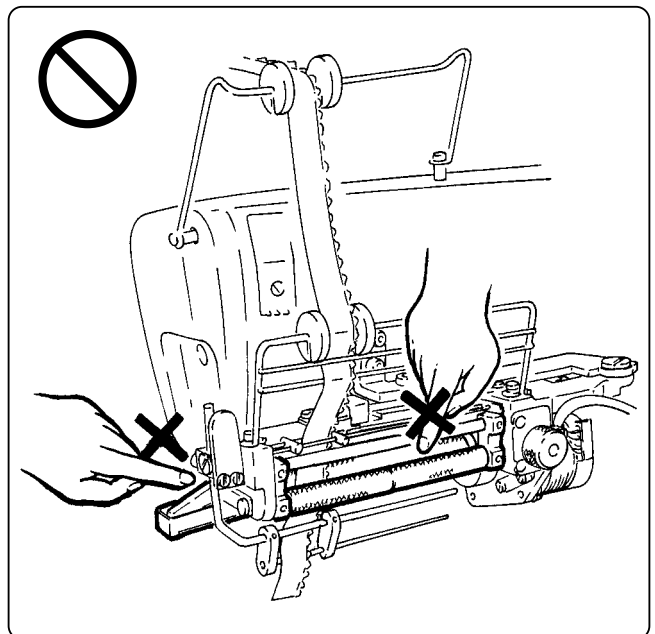

Application and performance

The MD441, 641, 643 is an elastic lace feeder for attaching elastic lace to panties, lingerie and similar garments.

All you have to do is enter sewing data into the controller, then inserting and attaching elastic lace are just as easy as plain seaming.

26 programs (items) from A to Z (kinds and/or sizes of garments) can be entered and stored. Up to five patterns per item (sections to be sewn in a garment) can be entered and stored. Where to operate the tape cutter (at the start or end of sewing) can be programmed in each pattern (1 to 5). In addition, up to seven steps (changing where to use fullness application and the amount of fullness application during sewing) can be programmed and stored. When switching steps, you can select either MANUAL (switching by the knee switch) or AUTO (switching by stitch counting) mode as you require.

Note : The tape cutter function is optional on MD441.

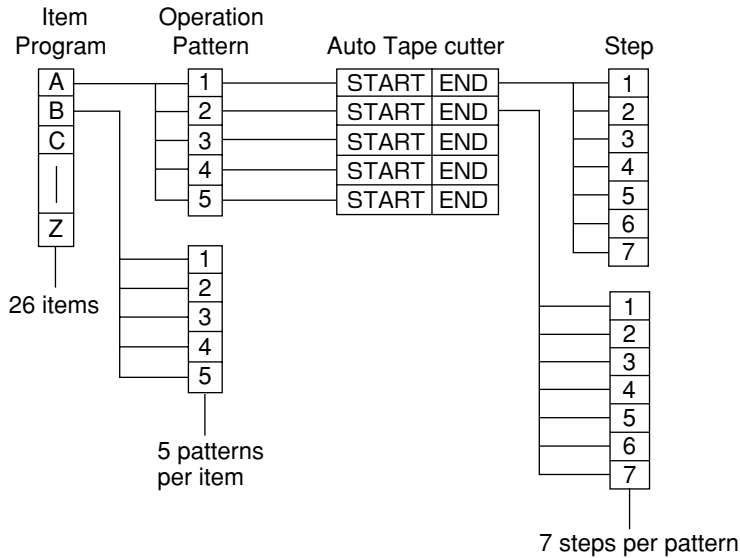

Feeding amounts and stitch counts can be entered into up to seven steps. The device can be used with only one step.

■ PROGRAM (items : kinds and/or sizes of garments) 26 items from A to Z can be entered.

For example, if elastic of the same width is used, program items as shown below.

Ex.

● Program 2 kinds of items (A, B) for leg openings of different bottoms of panties.

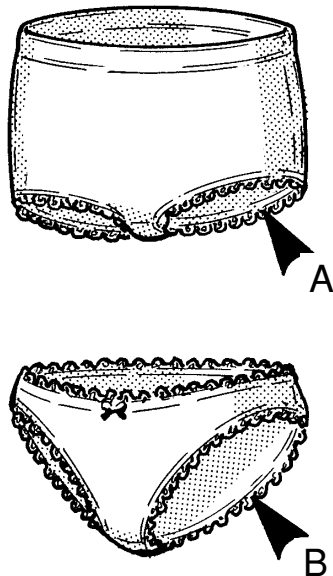

● Program 2 kinds of items (C, D) for leg openings of different bottoms of lingerie.

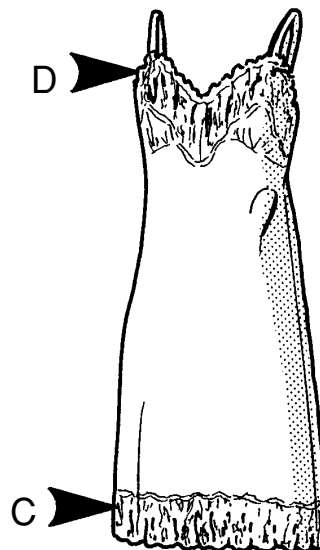

- 26 items from A to Z can be stored with up to five patterns (operations) per item.
For example, leg opening on the right, leg opening on the left.

Ex.

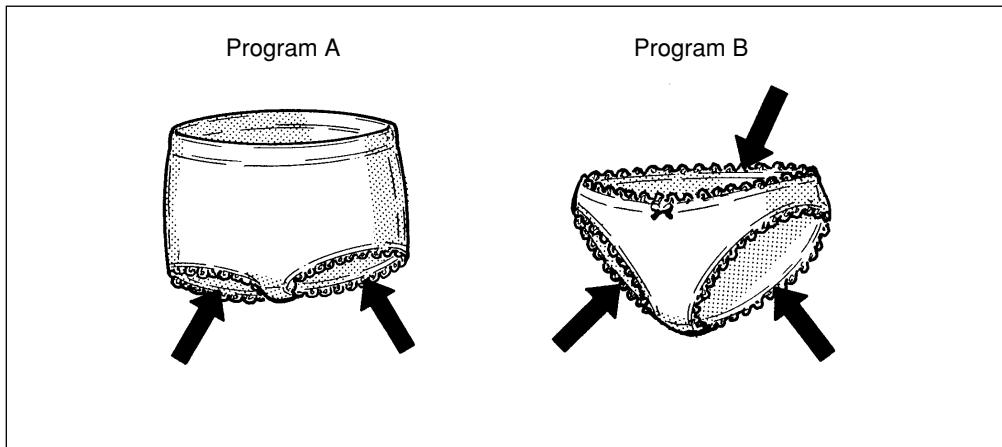

- One to five patterns (operations) can be stored with up to seven steps.

Ex.

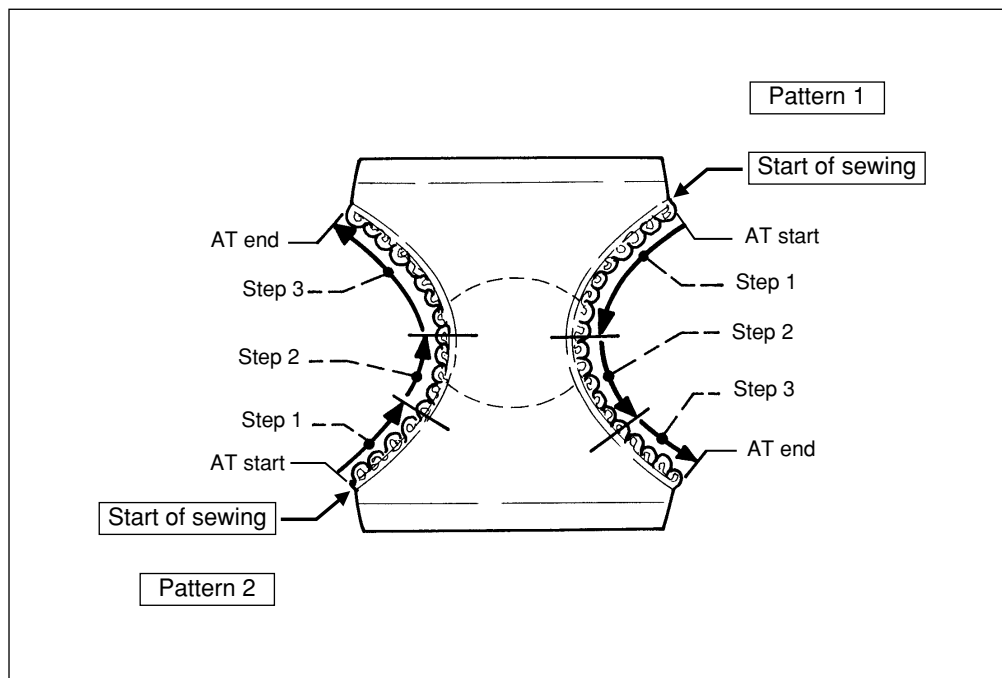

System construction

* The knee switch and the filter regulator can be installed most conveniently.

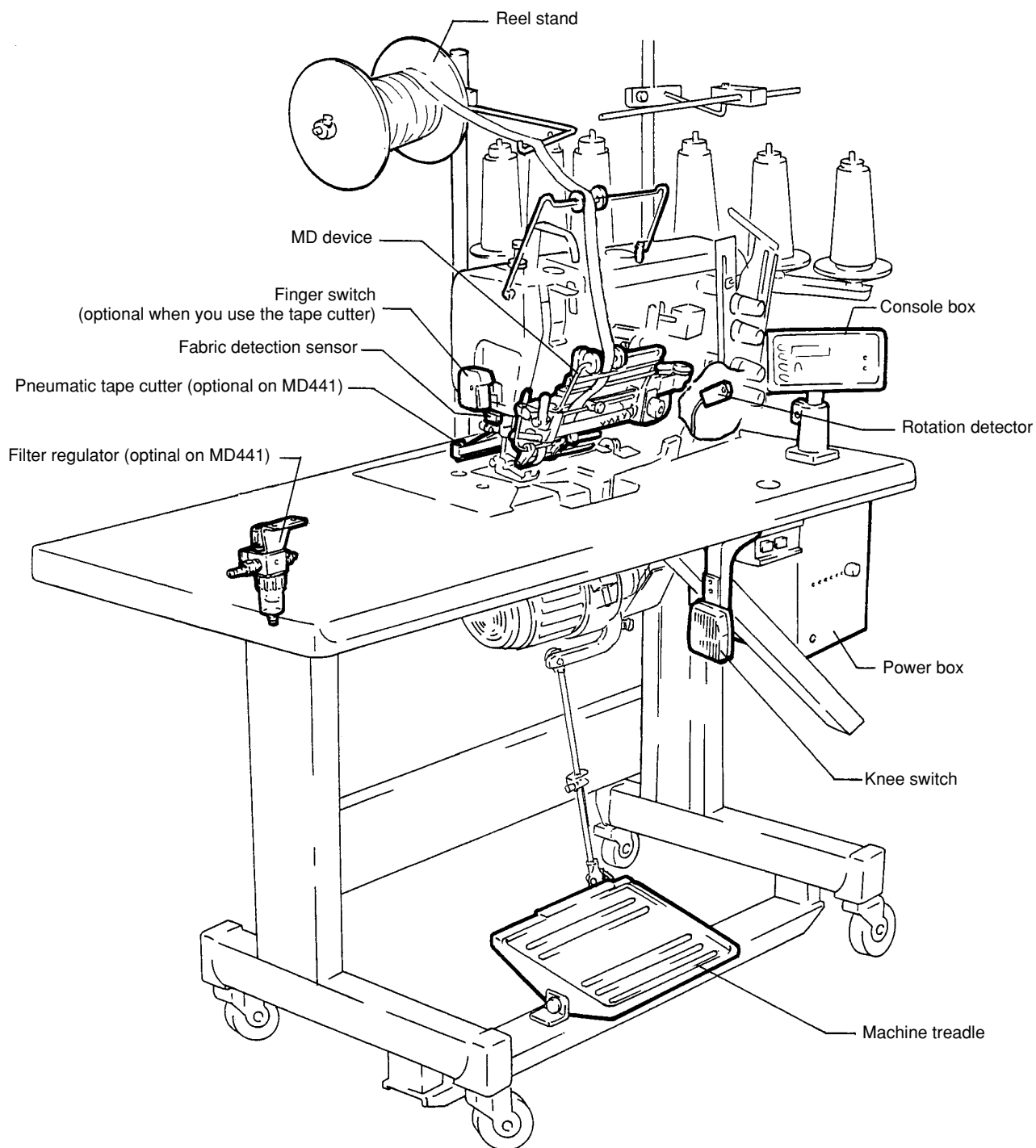

Installing each component

1. Installing the console box

⚠ CAUTION

 Always turn off the power, unplug the machine from the outlet and then well qualified technicians should install the console box.

1. Install console box 1 on bracket 2.
2. Mount the console box bracket on the machine table.

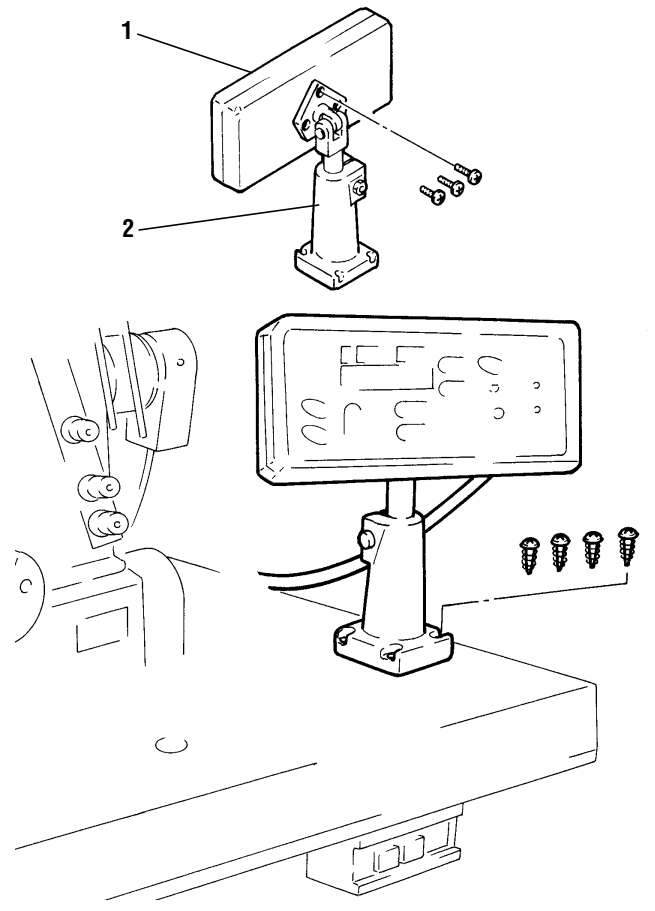

2. Installing the power box

⚠ CAUTION

 Always turn off the power, unplug the machine from the outlet and then well qualified technicians should install the power box.

Install controller on the underside of the machine table.

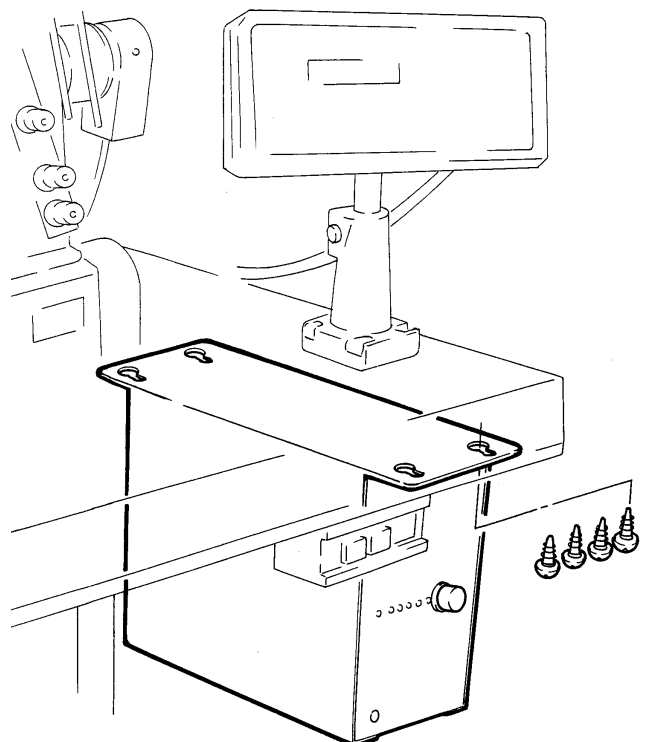

Installing each component

3. Installing the reel stand

CAUTION

 Always turn off the power, unplug the machine from the outlet and then only well-qualified technicians should install the reel stand.

Install the reel stand on the machine table.

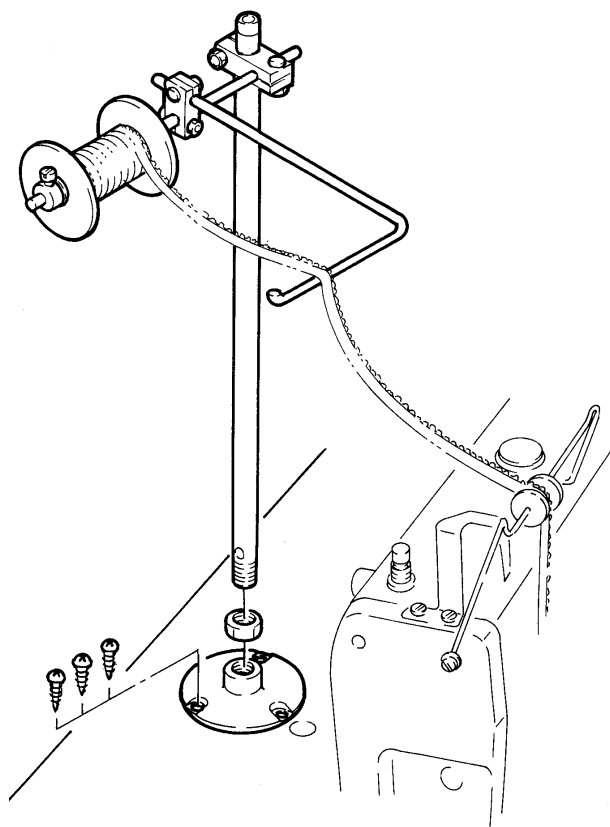

4. Installing the knee switch

CAUTION

 Always turn off the power, unplug the machine from the outlet and then only well-qualified technicians should install the knee switch.

Install the knee switch conveniently on the underside of the machine table.

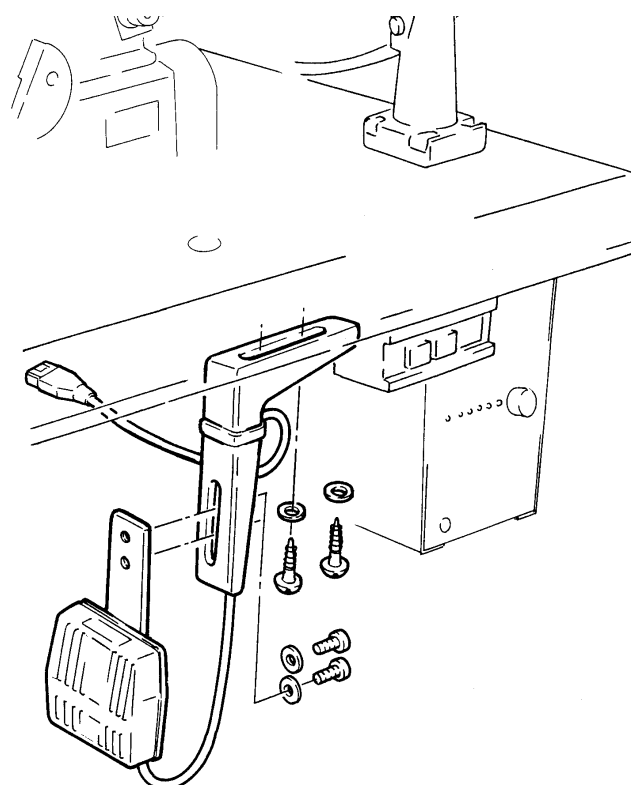

Installing each component

5. Installing the finger switch (option)

Note: The finger switch is optional when you use the tape cutter.

CAUTION

 Always turn off the power, unplug the machine from the outlet and then only well-qualified technicians should install the finger switch.

Install the finger switch by referring to the illustration.

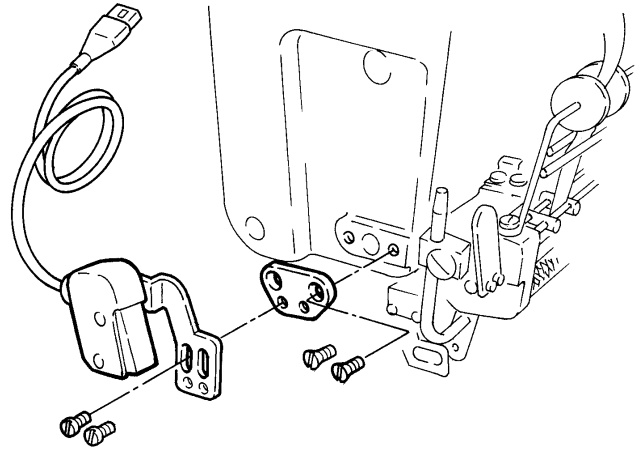

6. Installing the filter regulator

Note: Optional on MD441.

CAUTION

 Always turn off the power, air compressor first and then only well-qualified technicians should install the filter regulator.

 Connect other lines first before connecting to the air source (air compressor).

Install the filter regulator on the underside of the machine table.

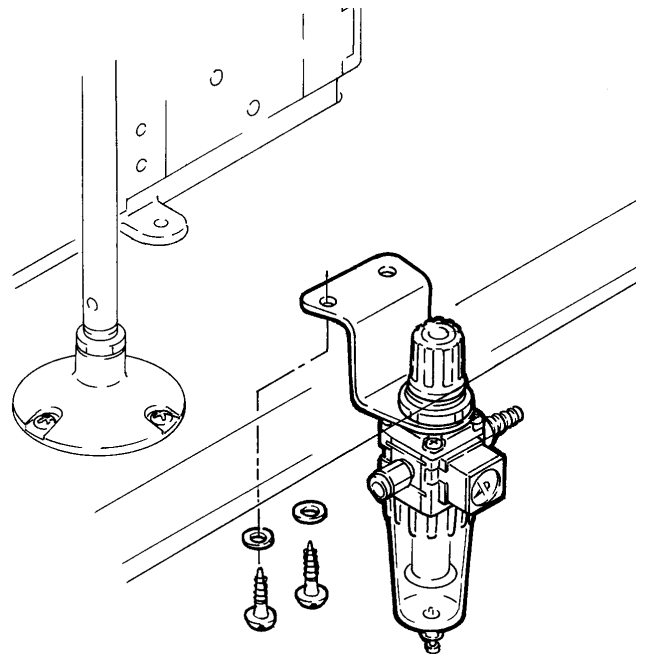

Description of MD power box

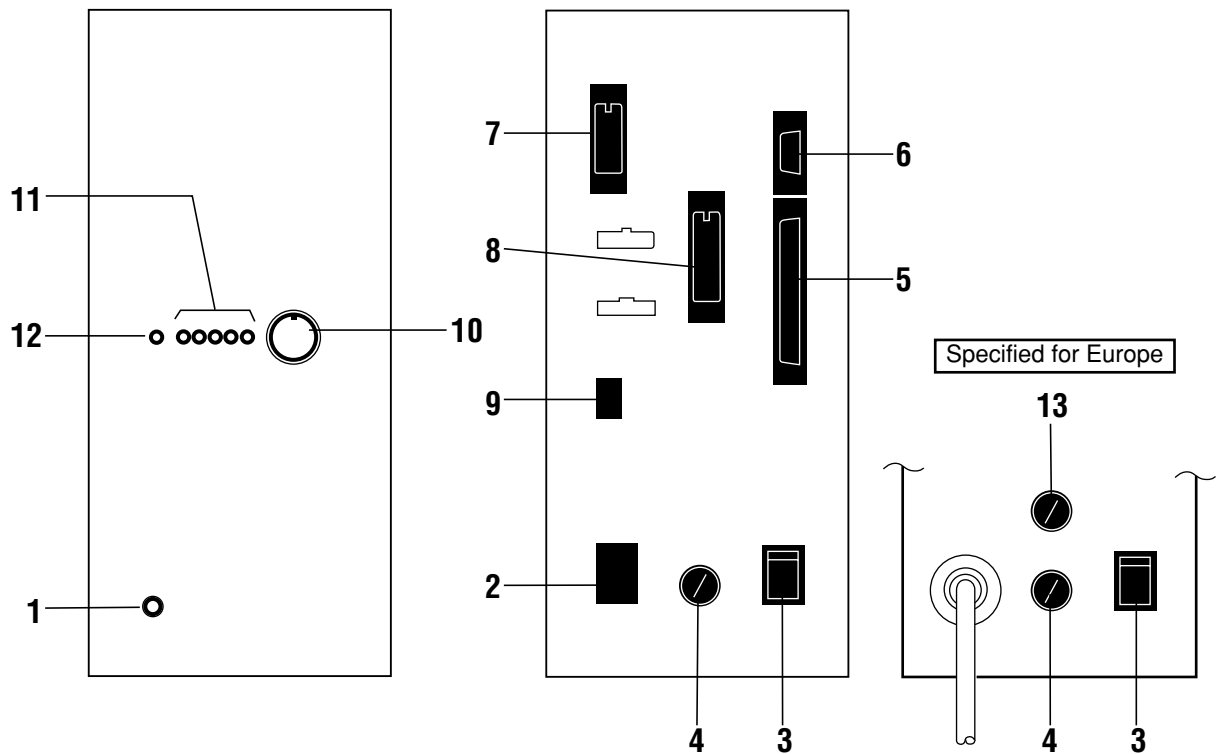

1 LED for power source

Indicates the power is on/off.
Lit when the power is on.

2 Power connector (input)

To connect the power cord.

3 Power switch

To turn ON or OFF the power of the MD power box.

4 Fuse holder

3A fuse is included.

5 Console box connector (input/output)

To connect cords from the console box.

6 Sensor connector (input)

To connect the relay cord for the rotation detector and fabric sensor.

7 Input switch connector (input)

To connect the relay cord of the knee switch, finger switch (optional for the tape cutter) or tape cutter (optional on MD441).

8 Out put connector (output)

To be connect to the relay cord of the tape cutter solenoid valve (optional on MD441) or machine motor (used when you want the machine to stop at the end of sewing).

9 Stepping motor connector (output)

To connect the elastic lace feed stepping motor relay cord.

10 Fabric detection sensor sensitivity adjusting dial

To adjust the sensitivity of the fabric detection sensor.

11 Fabric detection sensor sensitivity indicator lights

To check the sensitivity of the fabric detection sensor.

12 Fabric detection lights

To indicate the fabric sensor is detecting the fabric.

13 Fuse holder intended for users in Europe

3A fuse is included.

How to connect when you use the automatic stop function

Check to see if the terminal for the motor optional function such as the standard or emergency stop is positioned correctly (see the illustrations below). Then connect the cord to the motor connector properly. The cord and connector are supplied with the motor.

* If you use different motors than the motors shown below, follow the respective instruction manuals.

Black cord : 0 V
White cord : Standard stop or emergency stop

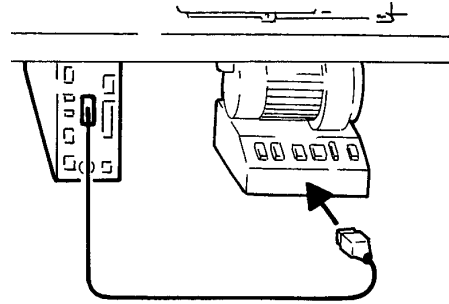

- Mitsubishi UT motor cord
- Panasonic UT motor cord

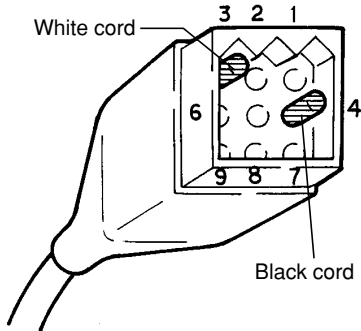

Cord side

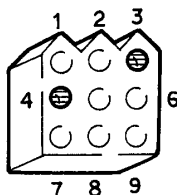

Motor side

- Mitsubishi standard AC servo motor

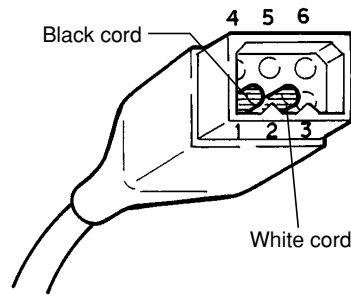

Cord side

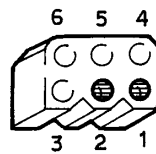

Motor side

- Panasonic standard servo motor cord

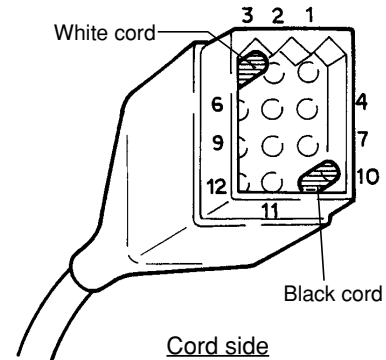

Cord side

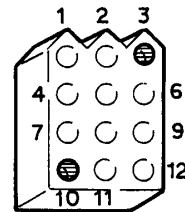

Motor side

Replacing the fuse for the power box

⚠ WARNING

Be sure to turn off the power and disconnect the power from the outlet, and then well-qualified technicians should replace the fuse.

⚠ CAUTION

The fuse for the MD power box is 3A. Do not use any other than 3A.

If the replaced fuse is blown out, the MD power box may be malfunctioning. Stop using the MD power box and contact your local Pegasus' sales office or representative.

Remove fuse holder cap 1 with the screwdriver by turning in the direction of the arrow, and replace the fuse 2 with a new one.

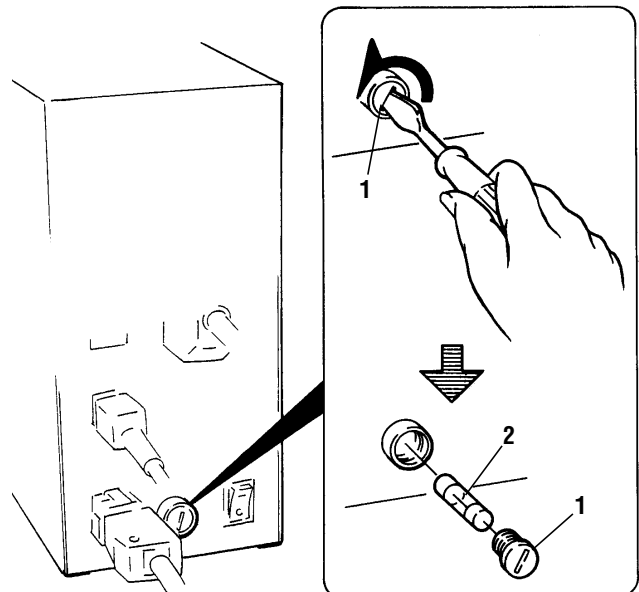

Connecting air lines and adjusting the filter regulator

Connecting air lines

CAUTION

Always turn off the power and air compressor first and then only well-qualified technicians should connect the air lines.

Connect other lines first before connecting to the air source (air compressor).

Connect air line 1 (from the air source) to joint 2 and then fasten it with hose clamp 3. Then connect filter regulator 4 to solenoid valve 5 with air line 6.

Note

- Be sure to insert air line 6 into joints 7 and 8 as far as it will go. Make sure air line 6 cannot be removed from joints 7 and 8 by pulling air line 6.
- To remove air line 6, pull air line 6 while pressing release ring 9 straight to the depth.

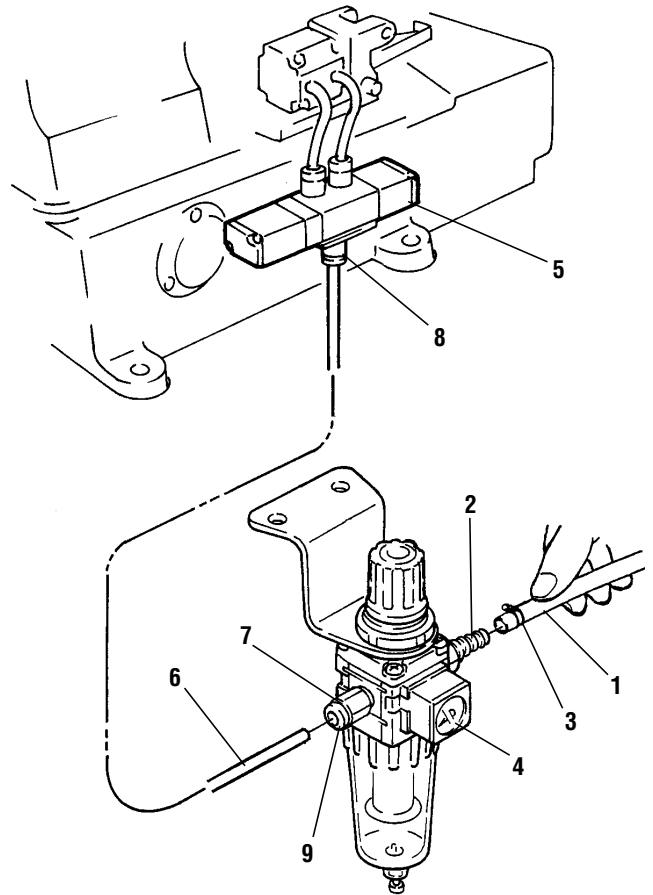

Adjusting air pressure

Pull up knob 10 on filter regulator until it clicks. Then set the air pressure at 0.5 Mpa (5 kgf/cm²).

- Turning 10 in the (+) direction increases the air pressure.
- Turning 10 in the (-) direction decreases the air pressure.

Draining the filter regulator

Drain the filter regulator before collected drainage reaches the level 11 by pressing button 12.

CAUTION

Be sure to drain periodically. Otherwise, drainage will flow into the solenoid valve and/or air cylinder, causing trouble.

Note that drainage and air spout out downward.

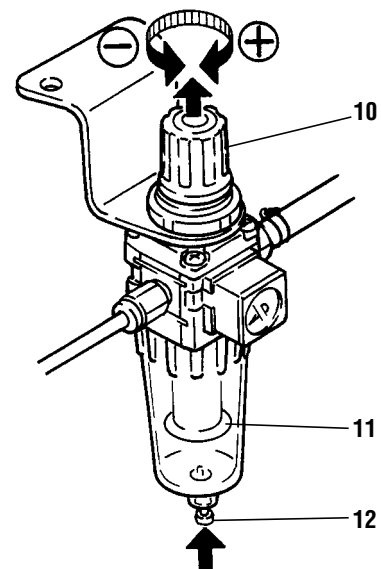

Inserting elastic lace

CAUTION

Be sure to turn off the power when inserting elastic lace. Be careful that your hands are not caught in the roller when performing the procedure.

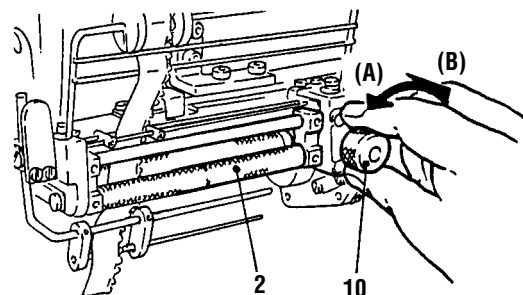
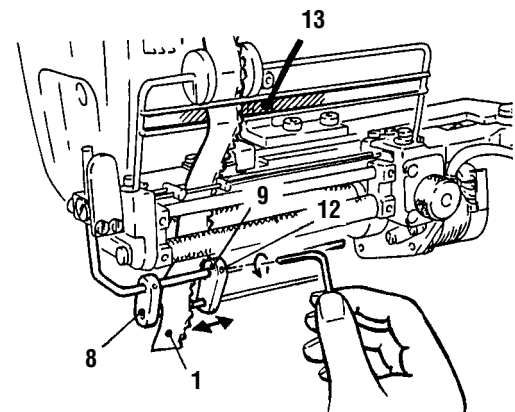
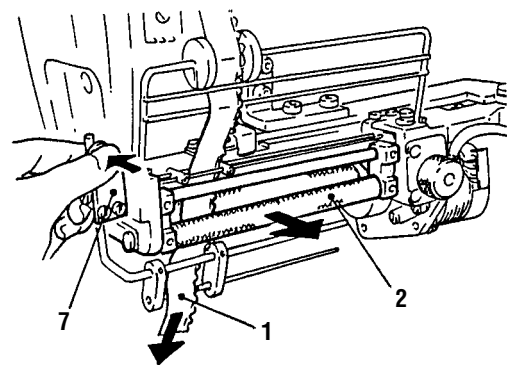
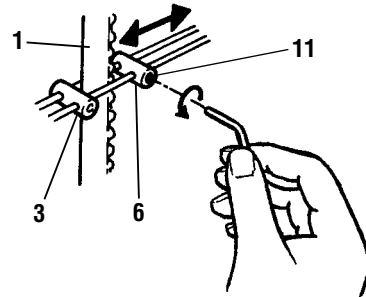
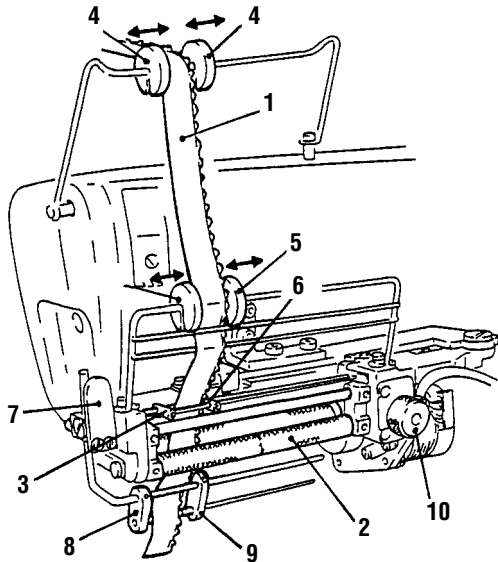

1. Insert the elastic lace 1 into roller 2 as shown in the illustration.
2. Adjust guides 4 and 5 so that elastic lace 1 can go through them smoothly. To make this adjustment, fit the left edge of the elastic lace to fixed guide 3 exactly first and move guides 4 and 5 as needed in the direction of the arrows.
3. Adjust guide 6 so that elastic lace 1 can go through guides 3 and 6 smoothly. To make this adjustment, fit the left edge of the elastic lace to fixed guide 3 exactly first. Then loosen screw 11 and move guide 6 as needed in the direction of the arrow.
4. Open roller 2 by pressing lever 7 and then insert elastic lace 1.
5. Adjust guide 9 so that elastic lace 1 can go through guide 8 and 9 smoothly. To make this adjustment, fit the left edge of the elastic lace to fixed guide 8 exactly first. Then loosen screw 12 and move guide 9 as needed in the direction of the arrow.

Note

Insert the elastic lace so that it will form a straight line as seen from the front of the machine.

6. Adjust roller 2 pressure so that the elastic lace can be fed properly. To make this adjustment, turn nut 10 clockwise or counterclockwise as required.
 - To decrease the pressure, turn in the direction of (A).
 - To increase the pressure, turn in the direction of (B).

Note

The above procedures are for reference. Use guide 13 as required according to the characteristics of the elastic lace.

Adjusting the guides according to the width of the elastic lace

CAUTION

Be sure to turn off the power when inserting elastic lace. Be careful that your hands are not caught in the roller when performing the procedure.

- Right lace guide 5 is set at the factory according to 20 mm elastic lace. Adjust guides 1, 2, 3, 4 and right lace guide 5 according to the width of the elastic lace. (see Fig. A)

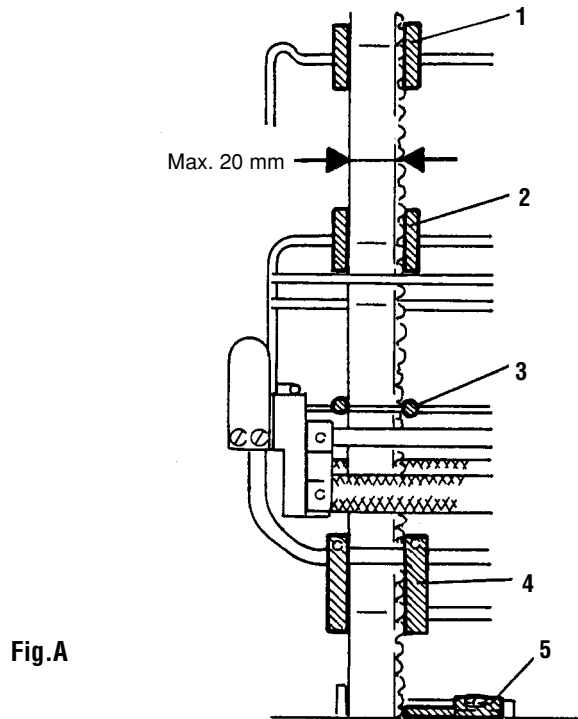
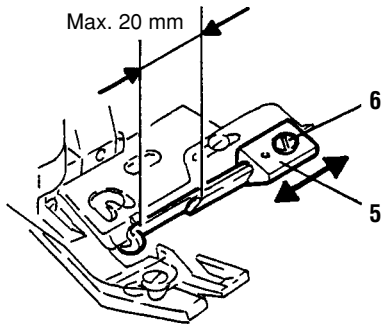

Fig.A

- For 20 - 38 mm wide elastic lace: Loosen screw 6 and move right lace guide 5 to the extreme right end. Then cut the left end of right lace guide 5 so that 38 mm elastic lace can go through easily. (see Fig. B)

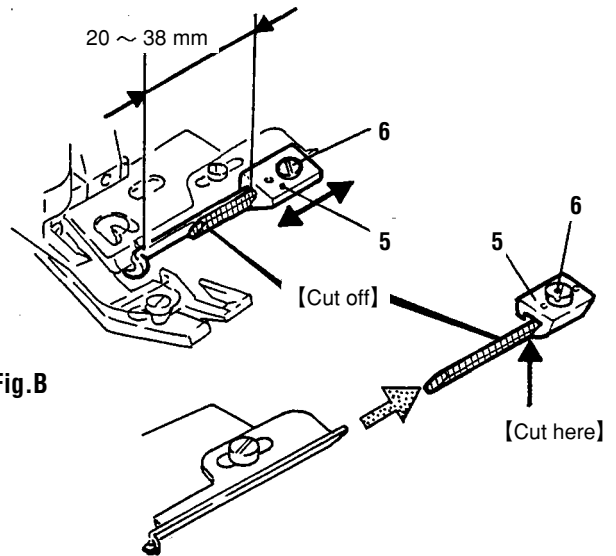

Fig.B

WARNING

To prevent accidents when cutting lace guide (right) 5, well-qualified technicians should perform the procedure, being careful not to injure their fingers and/or hands.

- For 38 - 92 mm (max.) wide elastic lace: Replace right lace guide 5 with lower lace guide assembly 7. Loosen screw 8 and adjust guide 9 according to the width of the elastic lace. (see Fig. C)

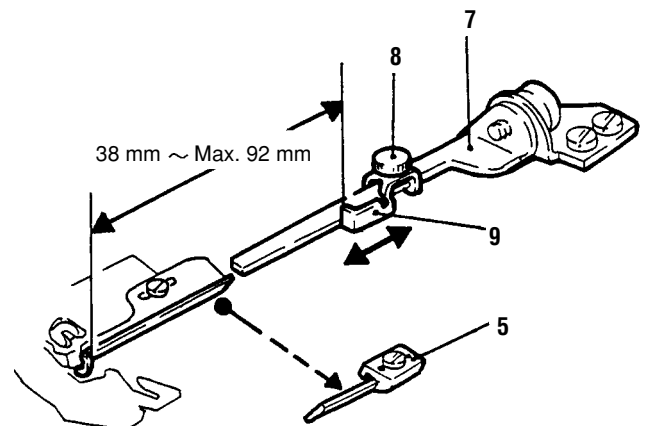
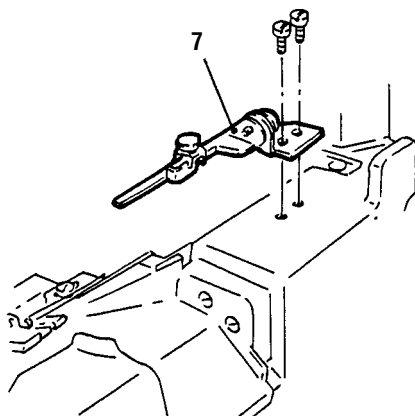



Fig.C

Functions of the machine treadle/external switches

Machine treadle

Pressing the treadle with toesStarts the machine.

CAUTION

 Pressing the treadle starts the machine even while the control panel is used to enter sewing data.

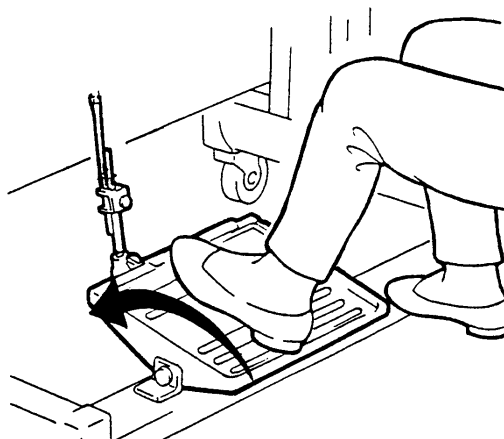

Knee switch

- In the MANUAL mode the machine goes to the next step by pressing this switch.
- In the AUTO mode steps cannot be changed by pressing this switch.

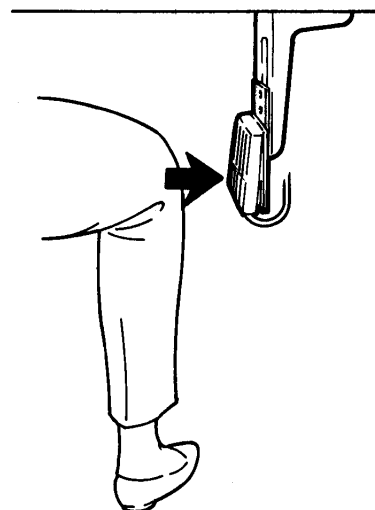

Finger switch (optional)

Pressing this switch operates the tape cutter.

Note

When you program the machine using the controller or if ON is not selected on the AT function (see page 25) on the function select mode, pressing the finger switch will not operate the tape cutter.

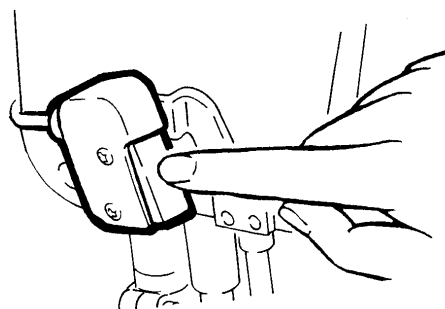

Adjusting the sensitivity of sensor

The fabric detection sensor detects the end of the fabric at the start of sewing so that the controller can count the number of stitches from the end of the fabric to a part of ruffling. Therefore switching a ruffling operation is correctly done.

To adjust the sensitivity of the sensor

CAUTION

Well-qualified technicians should adjust the sensor properly according to the fabric to be sewn. Otherwise the tape cutter could get activated unexpectedly during sewing.

1. Turn on power switches 1 and 2.
2. Ensure that no material is inserted when adjusting sensor
- 3.

3. Turn dial 4 until the fourth from the left of indicator lights 6 is turned on completely.

4. Turn dial 4 clockwise slowly and stop turning dial 4 until the fifth light is turned on.

Check the indicator lights carefully if they are turned on/off correctly with fabric or no fabric. (Confirm that the lamps indicated by 6 are all turned off when material is inserted.)

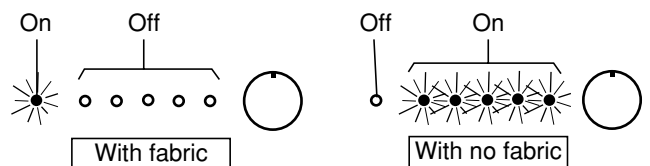
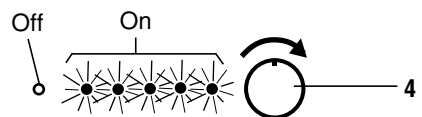
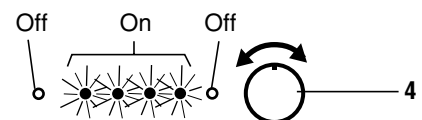
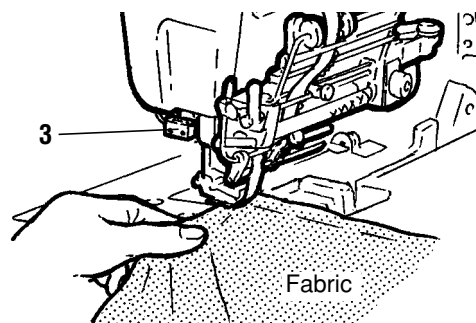
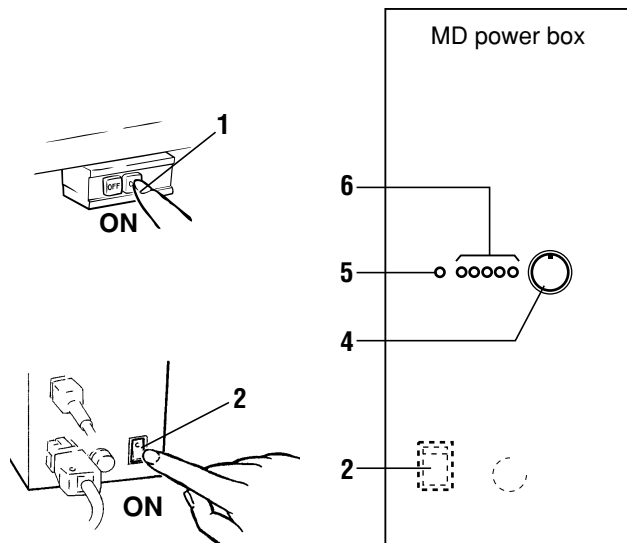

Note 1 : To sew special materials and/or extra light fabrics which the light from the sensor goes through, see below.

1. Turn dial 4 until the third from the left of indicator lights 6 is turned on completely.

2. Turn dial 4 clockwise slowly and stop turning dial 4 until the fourth light is turned on.

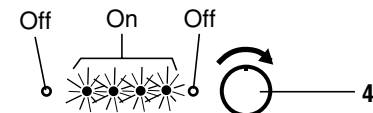
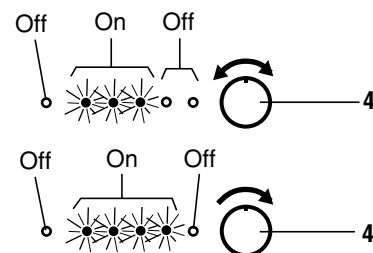

Note 2 : Clean the reflector on the top surface of the needle plate. Otherwise malfunction may occur.

Description of MD console box

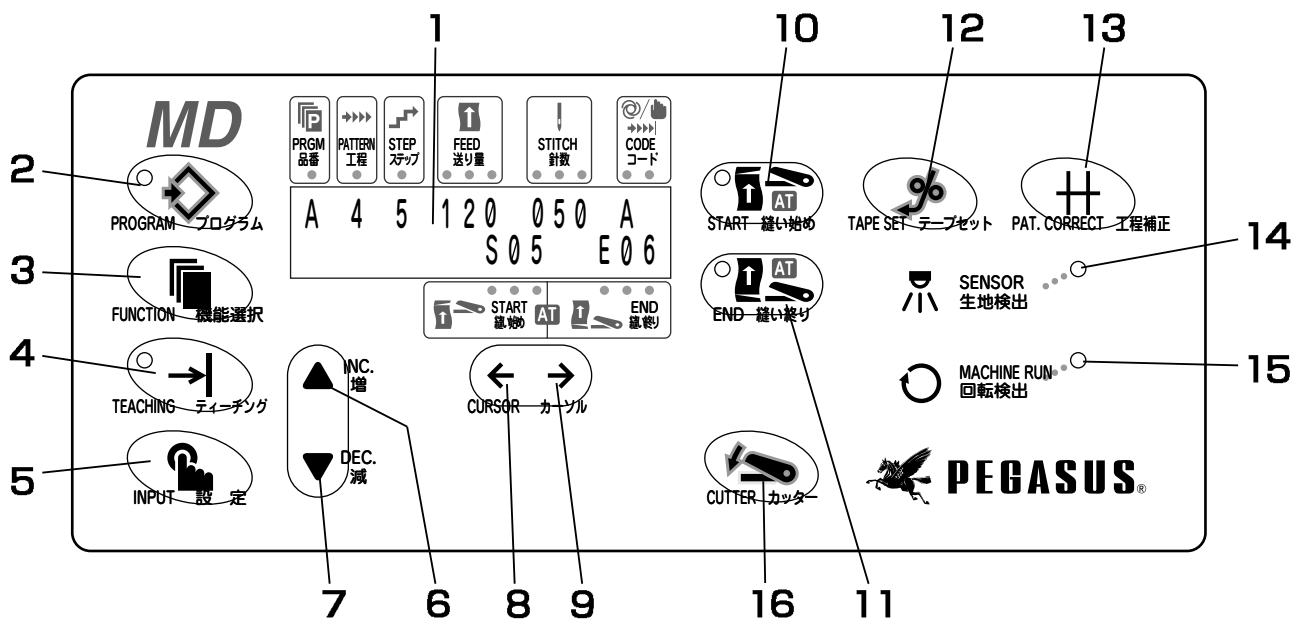

- 1** LCD (Liquid Crystal Display) screen
Displays various information.
*Select either Japanese or English.
- 2** PROGRAMMING key
To call up the sewing mode display in order to program operations, steps, feeding amounts, stitch counts and codes
- 3** FUNCTION key
To select each function or counter in the function mode.
- 4** TEACHING key
To teach the machine where to change each step by stitch counting during actual sewing after entering sewing data for an operation, step, feeding amount ("Teaching" is available in the automatic sewing mode.).
- 5** INPUT key
To input the stitch count obtained in the teaching mode
- 6** INC. key
To increase the value on data
- 7** DEC. key
To decrease the value on data
- 8** CURSOR (←) key
To move the cursor on the screen to the left.
- 9** CURSOR (→) key
To move the cursor on the screen to the right.
- 10** AT START key
To select ON or OFF with the AT (automatic tape cutter) START function.
- 11** AT END key
To select ON or OFF with the AT (automatic tape cutter) END function.
- 12** TAPE SET key
To feed out tape/elastic manually.
- 13** PAT. CORRECT key
To return to the previous pattern.
- 14** Fabric detection sensor indicator light
Turned on when the fabric detection sensor detects the fabric.
- 15** Rotation detecting light
Lit while the machine is running.
- 16** CUTTER key
Pressing this key actuates the cutter.

Entering the sewing data

1. Before entry

Initializing the MD device

When the MD device is used for the first time, initialize the MD device first.

Note

It is not necessary to initialize the MD device at the start of each day.

CAUTION

 Since the power is turned on when initializing the MD device, the machine could start unexpectedly. To prevent accidents, perform the following procedures very carefully.

 Make sure cords and air lines are connected properly first. Then turn on the machine.

Turn on the power box while pressing INC. and DEC. keys ▲ · ▼ simultaneously.

The screen displays

Clear All Data セメントデータ ショウキョチュウ

Then all the sewing data is initialized.
(Refer to the sewing data preset at the factory before shipment.)

Note

Even if the MD device is initialized, the language mode is not changed.

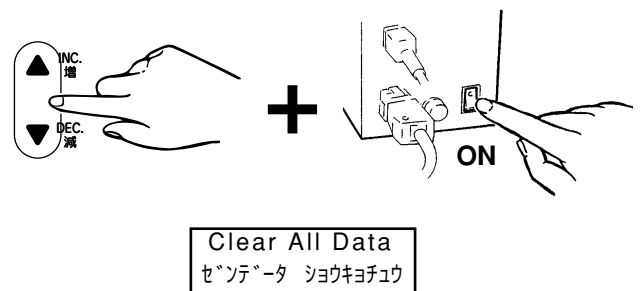

Entering the sewing data

2. Data entered at the factory

- The following data is factory-set. Change the data according to the fabric to be sewn.

Sewing data entered at the factory	Value which can be entered
Mode : Auto	Auto – Manual
Program (item) : A	26 items from A to Z
Pattern : 1	5 patterns from 1 to 5
Step : 1	7 steps from 1 to 7
Stitch count : 0 in all steps	0 to 999 stitches
Feeding amount : 0 in all steps	0 to 180
Piece Count : OFF	ON – OFF
Base Length : 030	0 to 150
Change of Item number : Mech. Level	With Mechanic level / Mechanic & Operator
Language to be used : English	Japanese / English
Rotation Check : OFF	ON – OFF
AT Start of sewing : OFF	ON – OFF
AT End of sewing : OFF	ON – OFF
Mesh counter : OFF	ON – OFF
Middle Cutting : OFF	ON – OFF



CAUTION

Initial setting : English

Therefore select Japanese or English as required when the controller is used for the first time.

3. Function selecting mode

- You can select each function or counter in this mode.

1. Turn on the machine while pressing PROGRAMMING

key .

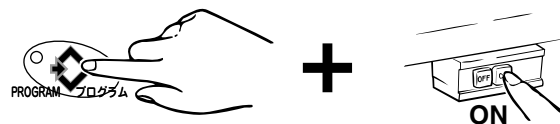

2. Every time you press FUNCTION key , the screen display can be changed sequentially and then each function can be switched.



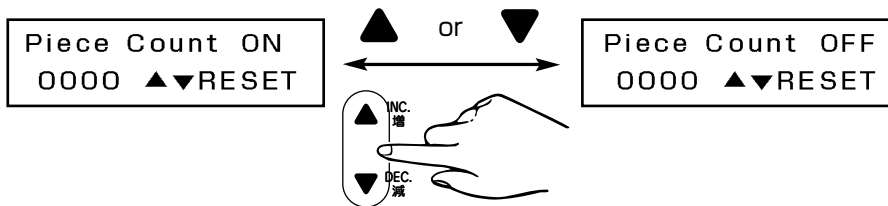

Display



Function

- To select ON or OFF with the output counter (Piece Count)
 - If you select ON, the output will be displayed on the screen.
 - To reset the value on the screen at "0000", press INC. and DEC. keys ▲ • ▼ simultaneously.

Switches

- ▲ or ▼ To select ON or OFF with the output counter
-  To go to the base length mode display
-  To return to the sewing mode display

Display

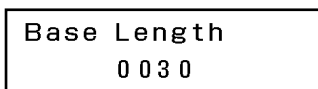



Function

- The initial value is 30.

CAUTION

 Programmable from 0 to 150. The factory set value is proper. Do not change it.

Switches

-  To go to the item number select mode display
-  To return to the sewing mode display

Change of Item number

Display

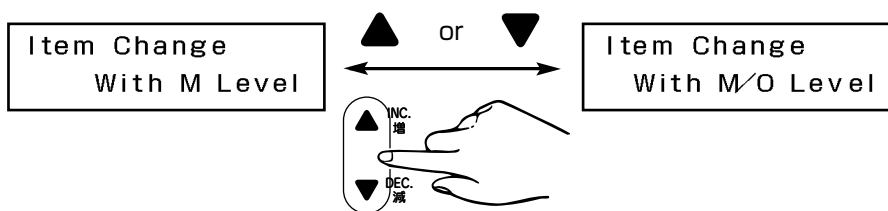





Function

■ To call up each item number

- Select either "Operator Level" or "Mechanic Level" display.
- If you call up the item number using "Mechanic Level" display, select "With M level".
If you call up the item number using "Operator Level" display, select "Mechanic & Operator".
- * Operator Level Available for operators.
- Mechanic Level Available for technicians to program (selecting or changing) each function.

( **CAUTION** Only well-qualified technicians should program each function.)

Switches

-  or  To select "Mech. Level" or "Mech. & Oper."
-  To go to the language select mode (Japanese or English) display
-  To return to the sewing mode display

Selecting a language

Display

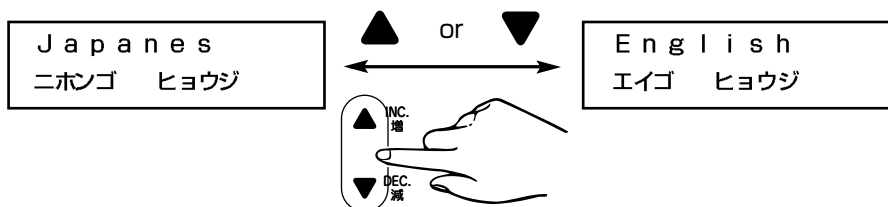





Function

■ Select Japanese or English

- * Initial setting : English
- The language to be used on the screen is either Japanese or English.

Switches

-  or  To select Japanese or English.
-  To go to the rotation check mode display
-  To return to the sewing mode display

Display

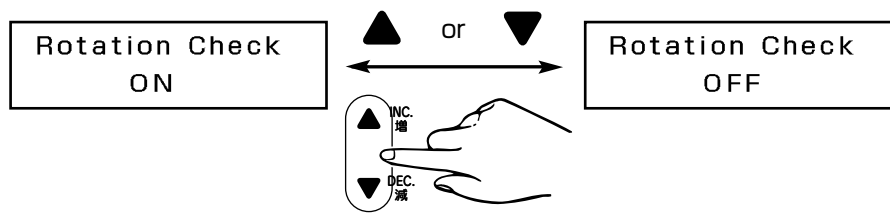

Function

■ To select whether you use the motor stop checking function or not

If you select OFF

As soon as the fabric has gone through the sensor, the machine will go to the next step.

If you select ON

If the fabric has gone through the sensor, the machine will not go to the next step until the motor stops.

Switches

▲ or ▼ To select whether you use the motor stop checking function or not



..... To go to the AT function mode display

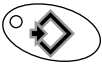

..... To return to the sewing mode display

Display

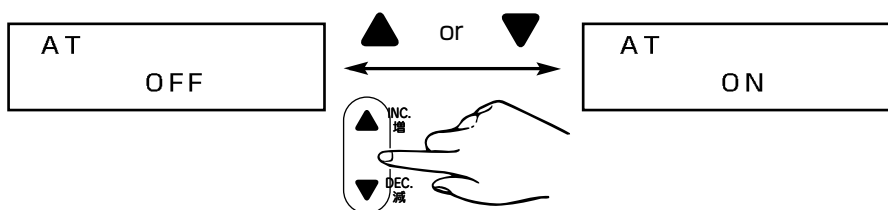

Function

■ To select whether you use the AT function or not

- If you use the AT function, select "ON".
 - * The motor automatic stop function can be used with the AT function "ON" (a relay cord for the motor optional function is needed). Regardless of "ON" or "OFF" in the AT END function mode (see page 32), the machine motor stops automatically at the value preset (by stitch counting) with the AT END function.
- If you do not use the AT function, select "OFF".
- The following 4 selectable cutter operation modes are available according to the seaming process and products (see page 32).

1. Double cutting ... The cutter operates automatically at the start and end of seaming.

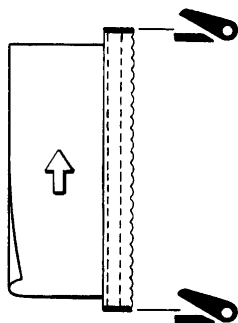

2. Front cutting ... The cutter operates automatically only at the start of seaming.

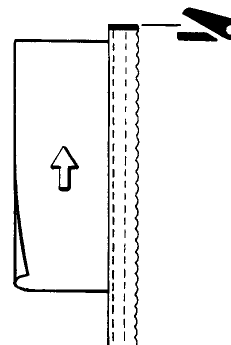

3. Rear cutting ... The cutter operates automatically only at the end of seaming.

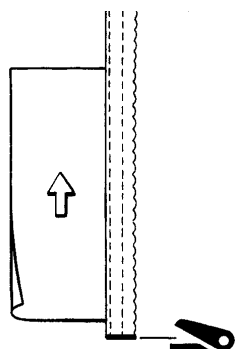

4. Manual You can actuate the cutter manually with the finger switch (option) or the key (on the console box). Be sure to operate the cutter with no fabric under the tape.

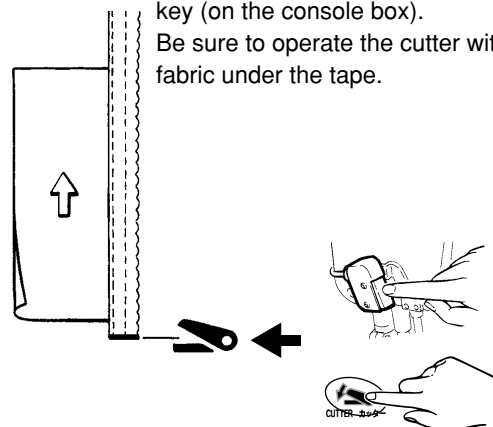

Switches

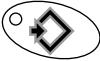
- ▲ or ▼ To select ON/OFF for the AT function
-  To go to the Mesh counter mode display
-  To return to the sewing mode display

Function selecting mode

Mesh counter

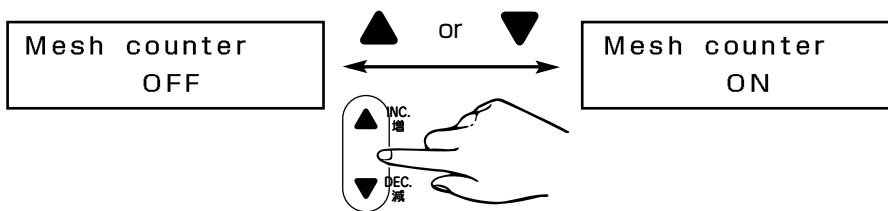

Display**Function**

- To program whether mesh fabric is sewn or not by selecting "ON" or "OFF"
 - If mesh fabric is sewn, select "ON".
 - If mesh fabric is not sewn, select "OFF". * Factory-set : "OFF"

CAUTION

⚠ Unless you use the fabric sensor, this function will be unavailable.

Switches

- ▲ or ▼ To select "ON" or "OFF" for Mesh counter
-  To go to the Mesh counter (stitch counting) mode display
-  To return to the sewing mode display

Function selecting mode

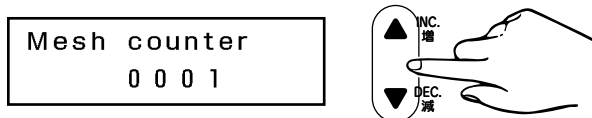

Mesh counter (stitch counting)

* Program this mode when "ON" is selected in the mesh counter mode.
This display is not shown with the mesh counter mode "OFF".

Display**Function**

- To program this mode when mesh fabric is sewn
 - To program the number of stitches with which the machine goes through the mesh fabric (since the fabric sensor determines the fabric has gone through the sensor by detecting a mesh hole, the machine cannot sew the fabric correctly. To prevent this, program the mesh counter with the number of stitches of the mesh hole so that the sensor will ignore it.)
 - Adjustable from 1 to 10. * Factory set 1 stitch

Switches

- ▲ To increase the number of stitches
- ▼ To decrease the number of stitches
-  To go to the Middle cutting mode display
-  To return to the sewing mode display

Display

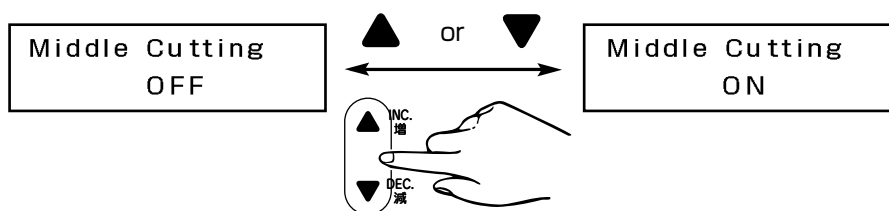

Function

■ To select "ON" or "OFF" with the "Middle cutting" function

○ If you select "OFF"

If you start sewing with the sensor interrupted by the fabric over the start of seam, the tape cutter will not get activated at the value preset (by stitch counting) with the AT START function (see page 32).

CAUTION

⚠ Make sure the light from the fabric sensor is interrupted properly by the fabric at the start of sewing. If the light from the fabric sensor is interrupted while the machine is running, the tape cutter will get activated as preset in the AT START function mode with the "Middle cutting" function "OFF". Be careful !

○ If you select "ON"

Even if you start sewing with the sensor interrupted by the fabric, the tape cutter will get activated at the value preset (by stitch counting) with the AT START function.

Switches

▲ or ▼ To select "ON" or "OFF" for the Middle cutting

 To return to the sewing mode display

 To return to the sewing mode display

Changing PGM (items)

4. Changing PGM (items)

To change the sewing data which has been already programmed. Follow the procedures below.

- *Operator level For operator
- Mechanic level . . . Only well-qualified technicians should program and change the function select mode

1. Turn on the machine while pressing PROGRAMMING

key  .

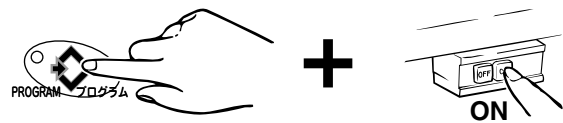

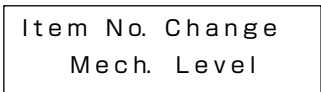

2. Press FUNCTION key several times to call up

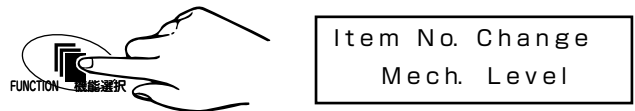
 on the screen.

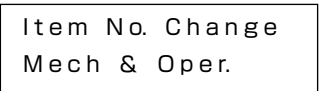

3. Press INC. or DEC. key ▲ · ▼ to call up

 and then press

PROGRAMMING key  again.



Any of 26 items from A to Z can be selected as required in order to be programmed.

To select, press INC. or DEC. key ▲ · ▼ .

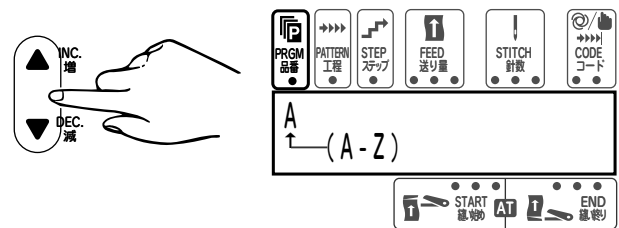

Sewing

Following the example shown below, enter sewing data.

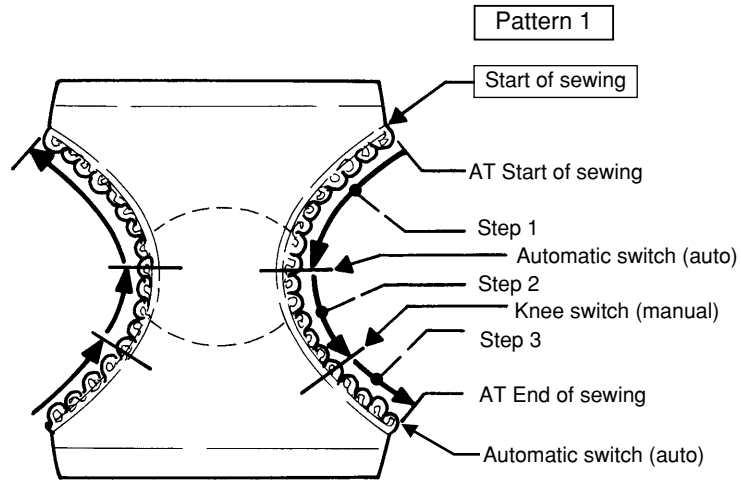

CAUTION

The numbers of feeding amount used for the above example are not actual. Enter the numbers according to your products.

Sewing

1. Programming patterns

1. Press PROGRAMMING key  to turn on the PROGRAMMING indicator light. The controller is ready for entry.

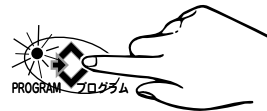

CAUTION

1.  The machine and/or the MD device would get activated by pressing the machine treadle during programming. Be careful.

2. Move the cursor to PATTERN and select PATTERN 1 by pressing INC. or DEC. ▲ · ▼ .

1 to 5 patterns can be programmed in sequence.

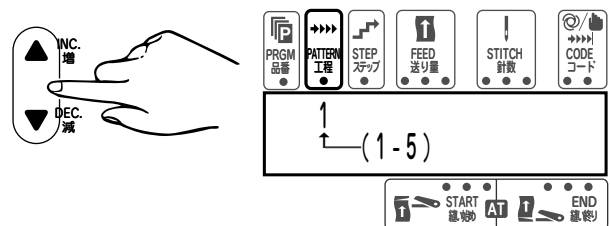

2. Programming steps

1. Move the cursor to STEP and select STEP 1 by pressing INC. or DEC. key ▲ · ▼ .
1 to 7 patterns can be programmed in sequence.

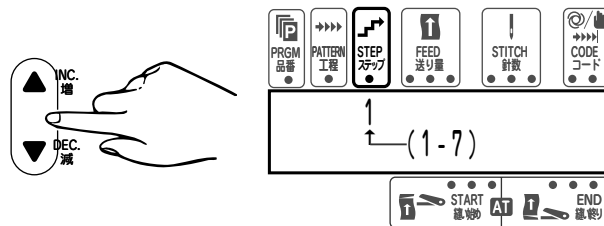

2. Move the cursor to FEED and enter the feeding amount by pressing INC. or DEC. key ▲ · ▼ .

Table 1

Feeding amount	Feeding distance
40	0.92 mm
50	1.15 mm
60	1.38 mm
70	1.61 mm
80	1.84 mm
90	2.07 mm
100	2.30 mm
110	2.53 mm
120	2.76 mm
130	2.99 mm
140	3.22 mm
150	3.45 mm
160	3.68 mm
170	3.91 mm
180	4.14 mm

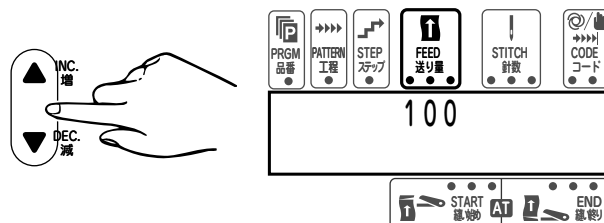

- 0 to 180 can be entered.
Feeding distances (see Table 1) are lengths which the machine can feed for one rotation.
- These distances are obtained by calculation, so they may vary according to the characteristics of the elastic and/or sewing manners.

3. Move the cursor to CODE (left) and call up A (auto) by pressing INC. or DEC. key ▲ · ▼ .

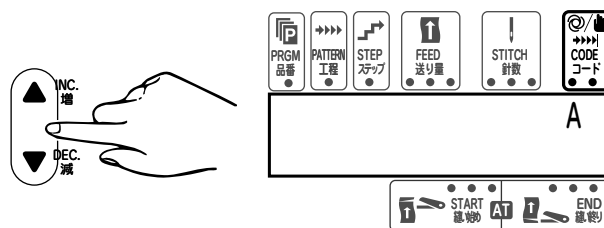

4. Move the cursor to STITCH and enter the number of stitches by pressing INC. or DEC. key ▲ · ▼ .

Note

If **M** (manual) is selected in procedure 3, no need to enter the number of stitches.

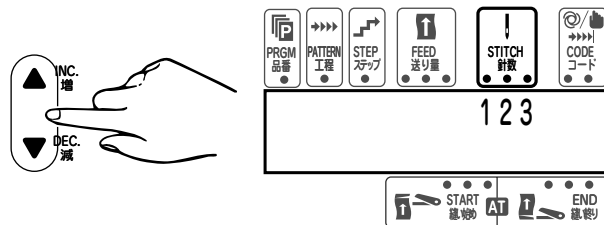

5. Move the cursor to STEP and call up 2 by pressing INC. key ▲ .

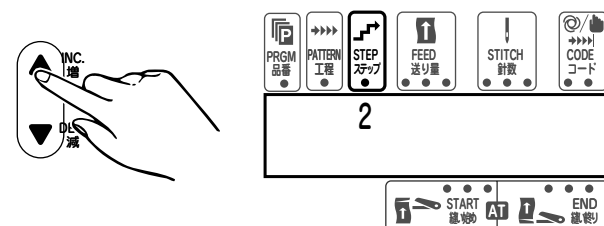

Repeat 2 to 5 procedures until STEP 3 has been programmed.

However, call up **M** (manual) for STEP 2 on the position of CODE (left) on the screen.

3. Finishing the program of step

1. Move the cursor to STEP and call up 4 by pressing INC. ▲ key.

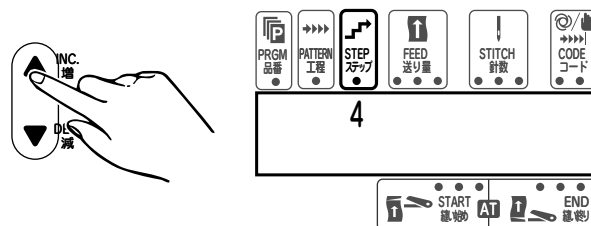

2. Move the cursor to FEED and keep on pressing both INC. and DEC. keys ▲ · ▼ until the number "000" is called on the position of FEED on the screen.

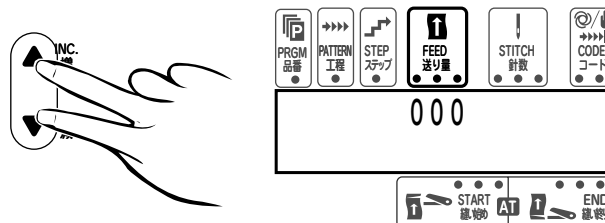

3. Move the cursor to CODE (left) and call up A (auto) on the position of CODE.

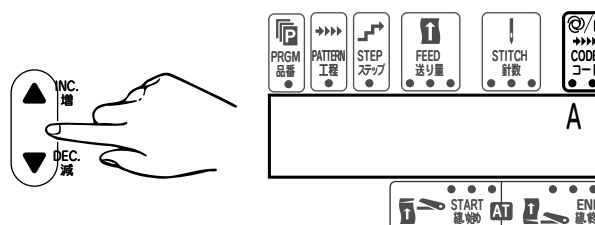

4. Move the cursor to STITCH and call up the number "000" by pressing INC. and DEC. keys ▲ · ▼ simultaneously.

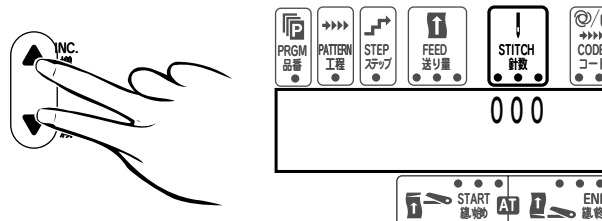

4. Programming the AT (automatic tape cutter)

With the automatic tape cutter function "ON", elastic tape can be attached continuously.

If you use the motor with standard stop mode, the machine can be stopped automatically whether the tape is cut or not at the end of sewing. To use the motor with the above mode, connect the specified relay cord to the connector (optional) on the machine motor control (see page 13).

*The above function is available with the AT function ON in the function select mode.

If the finger switch (optional) is adopted, the tape cutter gets activated every time you press the switch.

1. Press PROGRAMMING key  to turn on the PROGRAMMING indicator light.
The controller is ready for entry.

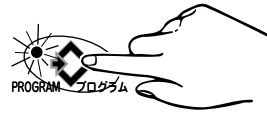

CAUTION

 The machine and/or the MD device would get activated by pressing the machine treadle during programming. Be careful.

2. Move the cursor to PATTERN.
Select a pattern in which the AT function is to be used by pressing INC. or DEC. key ▲ · ▼

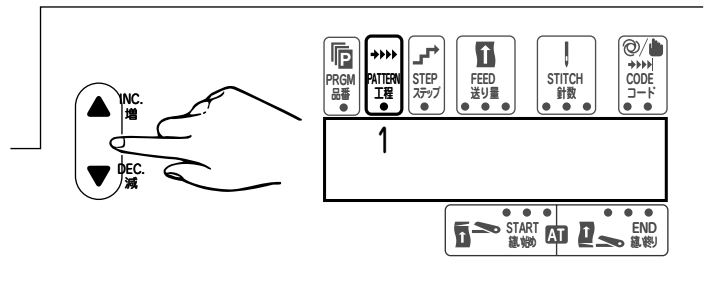

3. Move the cursor to START AT by pressing
FUNCTION key  once.



4. Enter the stitch count at which the tape is to be cut at the start of sewing by pressing INC. or DEC. key ▲ · ▼

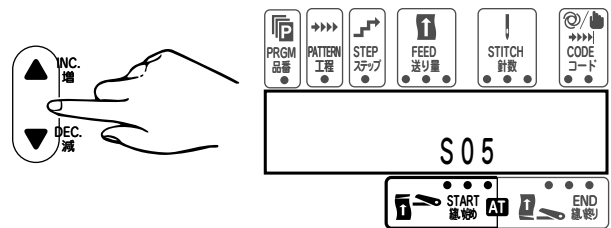

5. Press AT START key  to turn on the light.
Then the AT START function is available in the pattern selected above.



6. Move the cursor to END AT. Enter the stitch count at which the tape is to be cut at the end of sewing by pressing INC. or DEC. key ▲ · ▼.
*If you use the motor automatic stop function relay cord (option), the machine motor will stop automatically at the value preset with the AT END function regardless of ON or OFF in the AT END function mode.

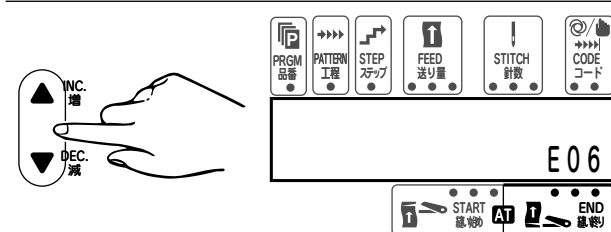

7. Press AT END key  to turn on the light.
Then the AT END function is available in the pattern selected above.



Programming PATTERN 1 is completed.

Before programming the next pattern, select whether sewing is completed with the current pattern or continued to the next pattern.

5. To continue to sew pattern after pattern

1. Move the cursor to CODE (right) and call up C by pressing INC. or DEC. key ▲ · ▼ .

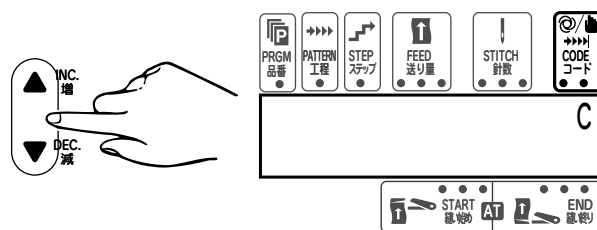

2. Press FUNCTION key  once.



3. Move the cursor to PATTERN and call up 2 by pressing INC. key ▲ .

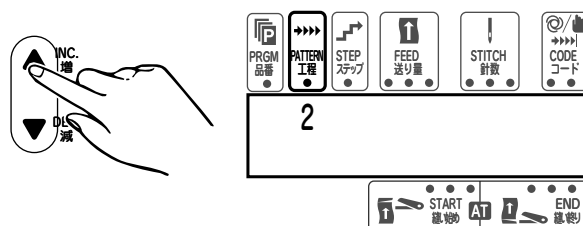

Then program each step by referring to the procedures for PATTERN 1.

6. To complete sewing when the current pattern is finished

1. Move the cursor to CODE (right) and call up E by pressing INC. or DEC. key ▲ · ▼ .

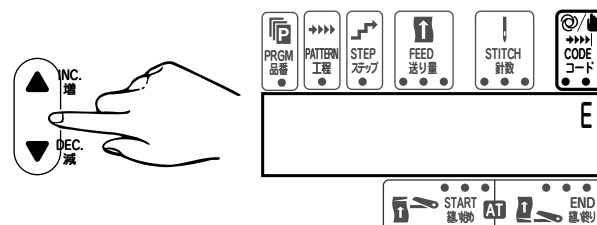

2. Press PROGRAMMING key  once to turn off the indicator light.
Then the sewing data entering mode ends.

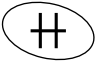

3. Press PAT. CORRECT key  several times to return to PATTERN 1.

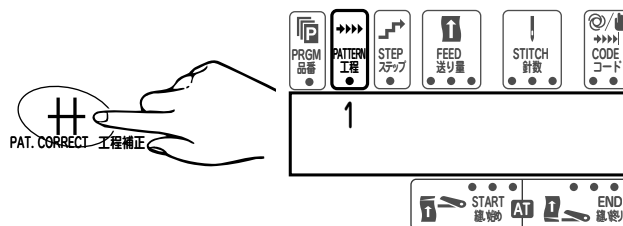

7. Teaching

Changing each step in the automatic mode is performed by stitch counting.

In this teaching mode the number of stitches can be entered by actual sewing.

Enter sewing data for an item, pattern, step, feeding amount, AT Start/End first and then follow the procedures below.

1. Make sure the machine is on.

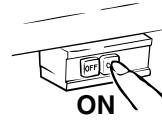

2. Select an item from A to Z by pressing INC. or DEC. key ▲ · ▼.

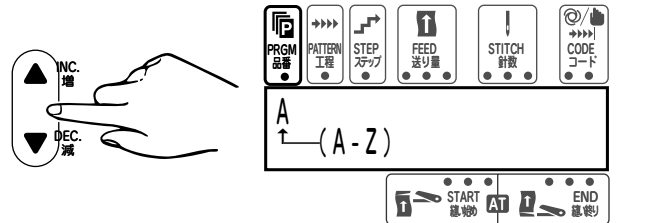

3. Select a pattern as desired by pressing PAT. CORRECT key  several times.

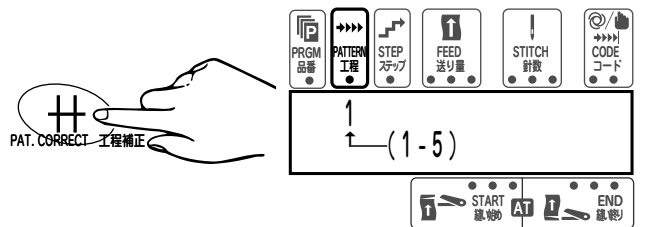

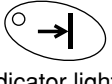
4. Press TEACHING key  to turn on the TEACHING key indicator light. Then the controller is in the teaching mode.

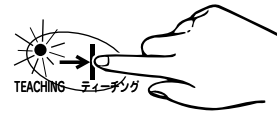

5. Position the fabric and start the machine. Stop the machine where to quit STEP 1. Then press INPUT key .

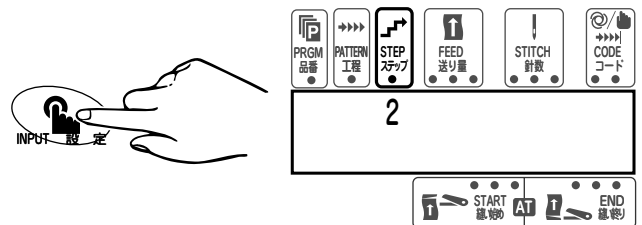

6. The number of stitches is stored. Go to STEP 2.

Note

When a ruffling operation and plain seaming operation are switched in each step manually, the numbers of stitches are not counted.

Therefore to go to the next step, press the knee switch.

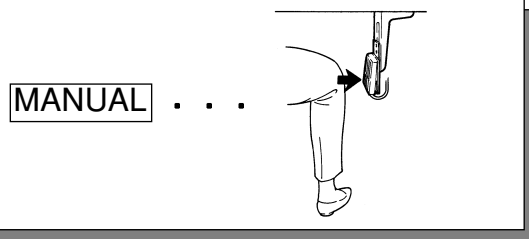

7. Start sewing in STEP 2.

Enter the stitch counts into each step by repeating the above procedures.

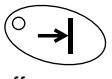
8. Press TEACHING key  to turn off the indicator light with the machine off.



Entry in this mode is completed.

8. Sewing

Two kinds of sewing modes (AUTO & MANUAL) are available.

●AUTO : Each step is automatically switched by stitch counting. (The number of stitches is displayed.)

●MANUAL : Each step is switched manually by pressing the knee switch. (The number of stitches is not displayed.)

Select AUTO or MANUAL mode when entering sewing data in each step for any pattern as desired. Then there is no need to select AUTO or MANUAL mode when starting the machine. Perform an actual sewing operation as shown below. The following procedures should be performed with elastic lace correctly inserted and the pneumatic tape cutter (optional on MD441) installed.

1. Turn on the machine.

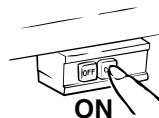

2. Call up an item (program) number to be sewn.

* Perform the procedures 2 to 3 by referring to "Changing PGM (items)" on page 28.

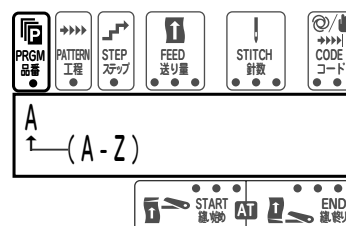

3. Position the fabric.

Note

The light from the sensor is interrupted by the fabric.

In this condition, whether the tape cutter gets activated at the start of sewing or not is determined by selecting ON or OFF in the Middle cutting function mode.

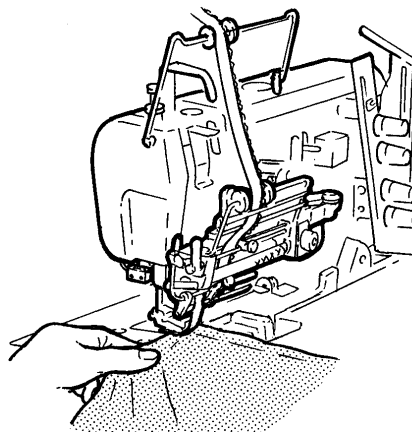

4. Press the machine treadle with toes.

Note

If you select "ON" in the AT START function, the tape cutter will get activated automatically at the start of sewing.

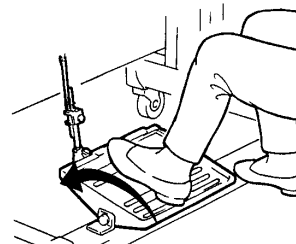

5. In the AUTO mode, switching each step is controlled by stitch counting. Therefore the machine goes to the next step automatically.

6. In the MANUAL mode, to go to the next step, press the knee switch.

MANUAL . . .

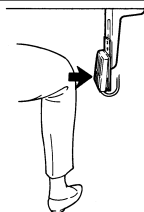

7. When the AUTO mode is selected at the last step, the cutter gets activated automatically.

When the MANUAL mode is selected at the last step, press the finger switch to cut the elastic lace.

Note

- If you select "ON" in the AT END function, the tape cutter will get activated automatically at the end of sewing.
- If both the AT function and the standard stop motor are used, the machine will stop automatically at the value preset (by stitch counting) with the AT END function, regardless of ON or OFF in the AT END function mode.

Check the first sewn product to see carefully if the machine runs properly :

- Increasing/decreasing the number of stitches is correct.
- Ruffling operations are performed as required.

After checking the above, change sewing data as needed.

Testing mode



Operation test

⚠ CAUTION

⊘ Do not turn off the power until the operation test display is shown. Otherwise memory may change.

If trouble occurs while the MD device is used, find the cause performing the test mode.

1. Turn on the power while pressing

PROGRAMMING  and FUNCTION  keys simultaneously.
The operation test display comes out.



2. Proceed according to the instructions.

【The instructions are displayed as shown below.】

1. Console box → 2. Input switches → 3. Input switches error → 4. AT cutter → 5. Stepping motor →
6. Rotation detecting sensor → 7. Fabric end detection sensor → 8. LED output

⚠ CAUTION

⚠ When any error message comes out, check the connection of cords/air lines and the pressure of the filter regulator, and then perform the test again. If the error is still shown, contact your local Pegasus' sales office or representative.

3. To restart sewing, turn off the power and then turn on the power again.

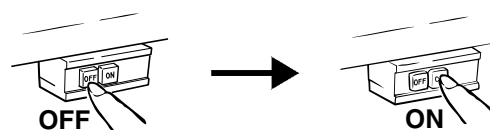

1. Console box

Press the key shown in the screen. Every time you press the key, the test screen will be displayed sequentially.

- Press PAT. CORRECT key  .

If there is nothing wrong, the display shown on the right will be displayed.

* If the error message or no message is displayed on the screen, check to see if the key shown in the display is pressed correctly.

- Press TAPE SET key  .

- Press AT START key  .
* Select "ON" with AT in the function select mode.
Otherwise the test cannot be performed.

- Press AT END key  .
* Select "ON" with AT in the function select mode.
Otherwise the test cannot be performed.

- Press CUTTER key  .
* Select "ON" with AT in the function select mode.
Otherwise the test cannot be performed.

- Press the right arrow key  .

- Press the left arrow key  .

- Press DEC. key  .

- Press INC. key  .

- Press INPUT key  .

- Press TEACHING key  .

- Press FUNCTION key  .

- Press PROGRAMMING key  .

..... SWITCH TEST
PUSH PAT CORR SW

..... SWITCH TEST
O K !

..... CONSOLE PANEL SW
SHORT ?

The switch test displays are shown on the screen as follows.

..... SWITCH TEST
PUSH TAPESET

..... SWITCH TEST
PUSH AT START

..... SWITCH TEST
PUSH AT END

..... SWITCH TEST
PUSH CUTTER SW

..... SWITCH TEST
PUSH CURSOR R SW

..... SWITCH TEST
PUSH CURSOR L SW

..... SWITCH TEST
PUSH DEC. SW

..... SWITCH TEST
PUSH INC. SW

..... SWITCH TEST
PUSH INPUT SW

..... SWITCH TEST
PUSH TEACHING SW

..... SWITCH TEST
PUSH FUNCTION SW

..... SWITCH TEST
PUSH PROGRAM SW

2. Input switches

- Press the knee switch.

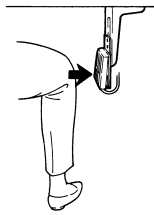

SWITCH TEST
PUSH RUFFLE SW

If there is nothing wrong, the display shown on the right will be displayed.

SWITCH TEST
O K !

3. Input switches error

If the input signal is abnormal, the following messages will be displayed.

- If the knee switch (fullness application changing switch) is under abnormal conditions
- If the cutter switch (finger switch) is under abnormal conditions

INPUT SIGNAL
SHORT ? (PB 2)

INPUT SIGNAL
SHORT ? (PB 3)

Note

If the above test messages or error messages are not displayed on the screen, check the input switch cable.

4. AT cutter

*Select "ON" with AT in the function select mode.
Otherwise the test cannot be performed.

- Press the finger switch (cutter switch) or CUTTER key (on the controller). The tape cutter will get activated.
- Press again the finger switch or CUTTER key in order to check to see if the tape cutter gets activated.

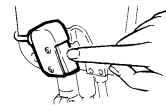

AT TEST 1
PUSH CUTTER SW

(Operate the tape cutter)



AT TEST 2
PUSH CUTTER SW





(Operate the tape cutter)

! WARNING



To prevent accidents, never bring your hands and/or fingers close to the tape cutter.

5. Stepping motor

1. While PROGRAMMING key  is pressed, the stepping motor rotates in the operating direction.
2. The display on the right is shown by releasing PROGRAMMING key .
3. While PROGRAMMING key  is pressed, the stepping motor rotates in the reverse direction.
4. Releasing PROGRAMMING key  calls up the rotation detecting sensor test mode.

```
PLS MOTOR TEST
FULL STEP +
```



```
PLS MOTOR TEST
FULL STEP -
```

6. Rotation detecting sensor

The rotation detecting sensor test message is displayed.

Run the machine.

If the rotation detecting sensor is OK, the message on the right will be displayed.

* If the OK message is not displayed, check the rotation detecting sensor.

```
..... OUTPUT TEST
RUN MACHINE
```



```
..... MACHINE RUN
SENSOR OK!
```

7. Fabric end detection sensor

Position the fabric after the fabric sensor test message is displayed.

Remove the fabric after the message on the right is displayed.

If the fabric sensor is OK, the message on the right will be displayed.

```
..... CLOTH SENS. TEST
INSERT MATERIAL
```



```
..... CLOTH SENS. TEST
REMOVE MATERIAL
```



```
..... SWITCH TEST
O K !
```

Note

If the test messages are not displayed as shown above, check the following.

- (1) Check to see if the fabric sensor cable is connected correctly.
- (2) Check to make sure the fabric sensor is adjusted properly.

8. LED out put

Press PROGRAMMING key  after the LED output test message is displayed.

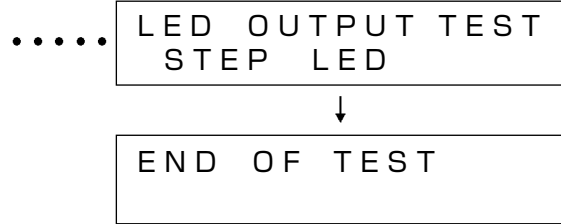

Note
Test end after this display.
There is no operation.

When output test is completed, the initial display appears on the screen.

Error message

If the following instructions are displayed while the MD device is being used, turn off the power and then turn on the power again.
If **【ERROR 3】** is displayed, turn off the power and initialize the MD device. (See page 21.)

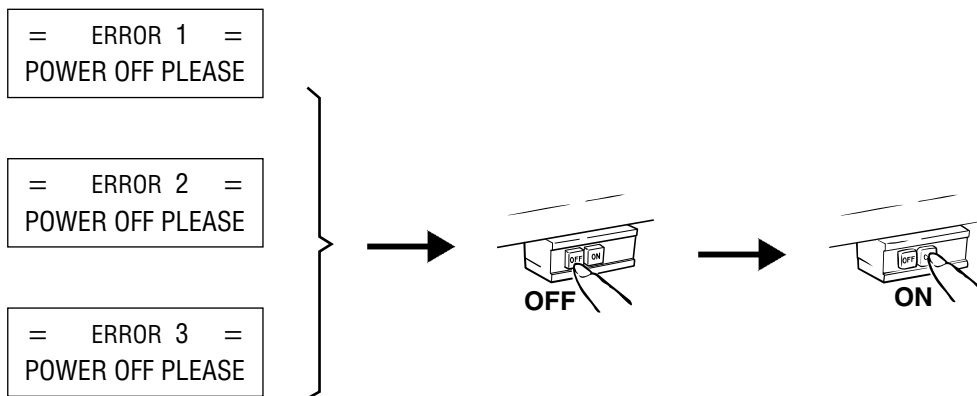

CAUTION

 If the above message is shown repeatedly, stop the machine immediately and turn off the power. Then only well-qualified technicians or service/maintenance personnel should check the device.

PEGASUS SEWING MACHINE MFG. CO., LTD.

5-7-2, Sagisu, Fukushima-ku, Osaka 553-0002, Japan. Phone : (06)6458-4739

Telefax : (06)6454-8785

© December 2001
Printed in Japan

The description in this INSTRUCTIONS is subject to change without notice.