

FW603EB

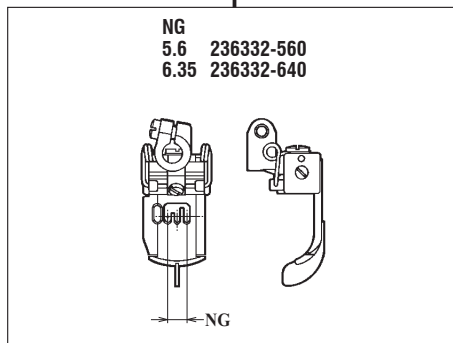

FW603 Series 共通部品 COMMON PARTS

ルーパー LOOPER
236501A0

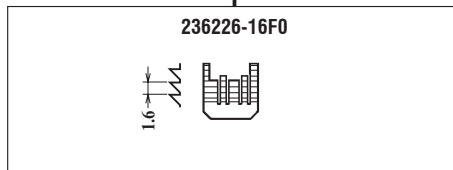
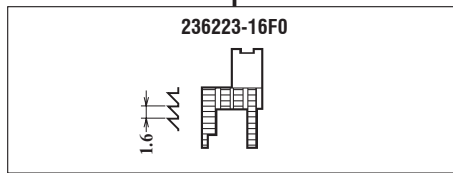
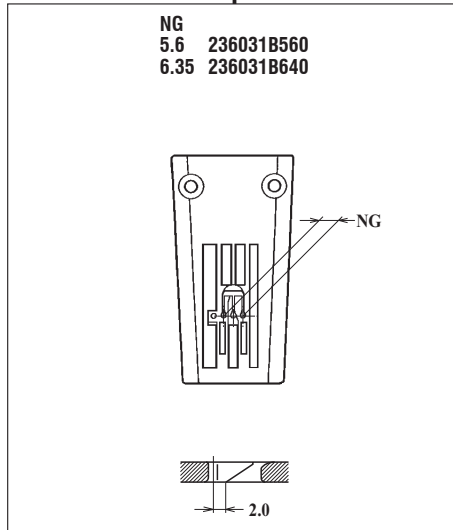
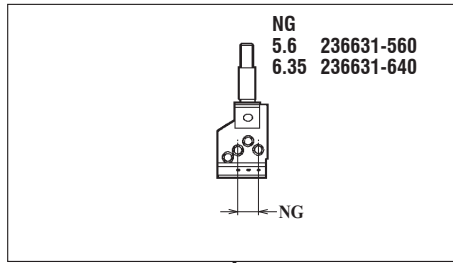

ルーパー補助器 LOOPER GUARD
2366240



針受(後) NEEDLE GUARD(REAR)
2366280



スプレッター SPREADER
207936A0

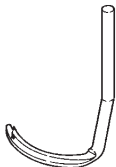

FW603EB × 356,364

カバーリング用つぶし縫い (中厚生地)
COVERING FOR FLATTENING
OUT OVERLOCK SEAMS
(MEDIUM WEIGHT FABRIC)

FW603FB,FC

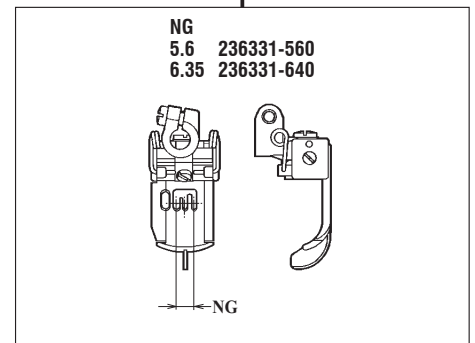
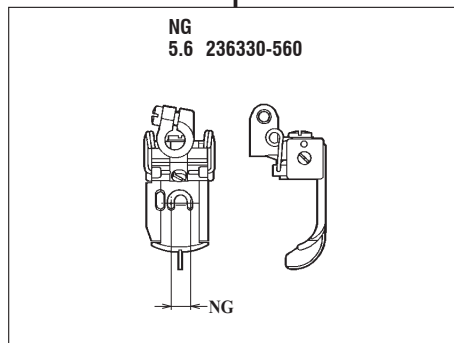
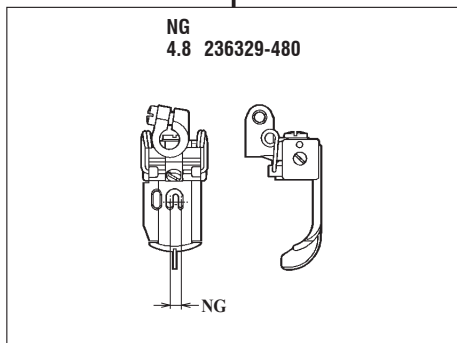
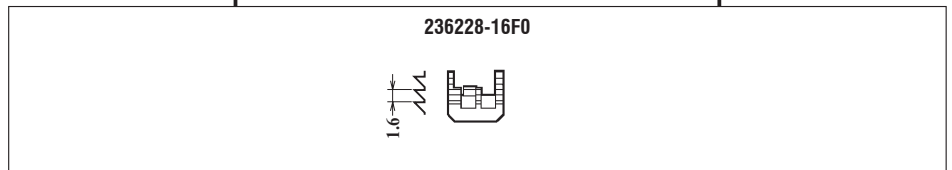
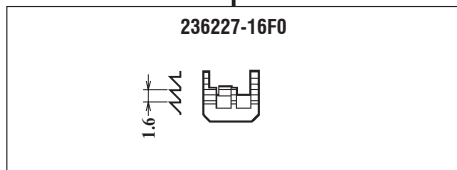
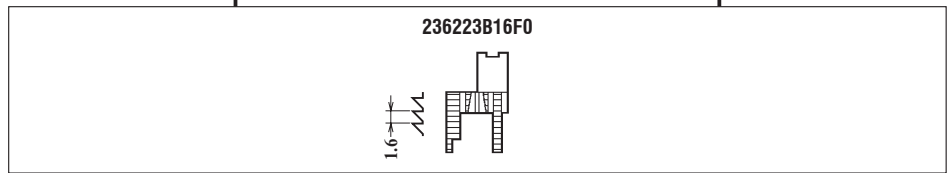
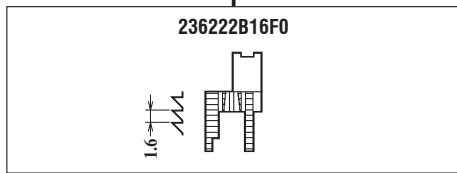
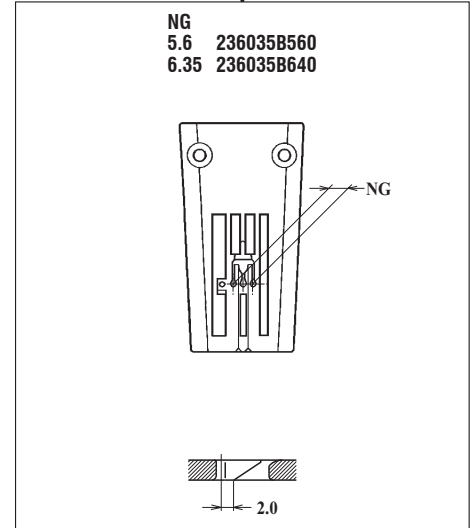
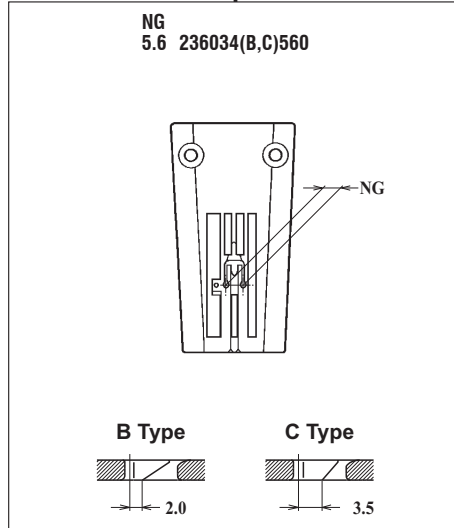
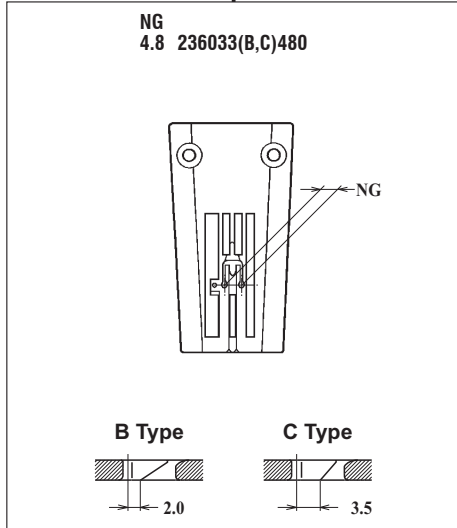
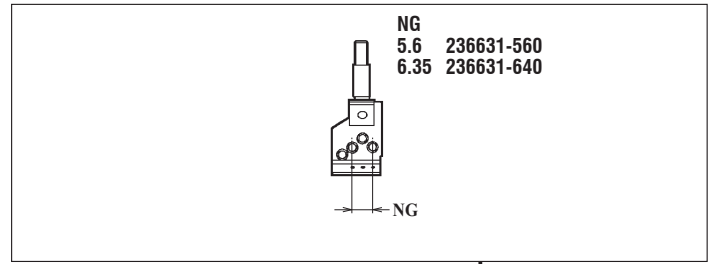
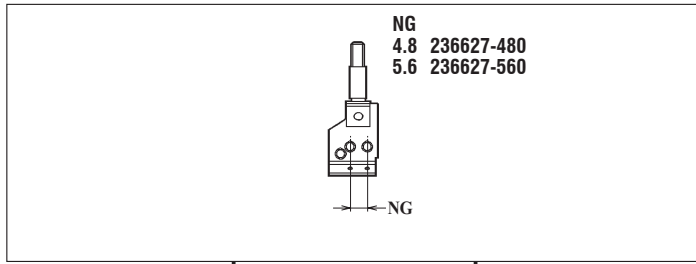

FW603FB,FC×248

カバーリング用つぶし縫い (厚生地)
COVERING FOR FLATTENING
OUT OVERLOCK SEAMS
(HEAVY WEIGHT FABRIC)

FW603FB,FC×256

カバーリング用つぶし縫い (厚生地)
COVERING FOR FLATTENING
OUT OVERLOCK SEAMS
(HEAVY WEIGHT FABRIC)

FW603FB×356,364

カバーリング用つぶし縫い (厚生地)
COVERING FOR FLATTENING
OUT OVERLOCK SEAMS
(HEAVY WEIGHT FABRIC)

機種 MACHINE	針板 NEEDLE PLATE
FW603FB	B TYPE
FW603FC	C TYPE

FW603GB,GC

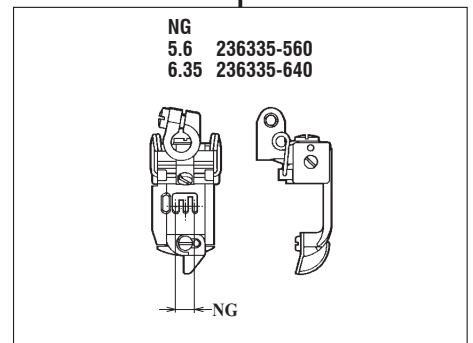
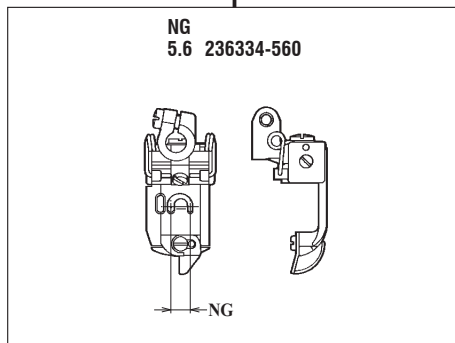
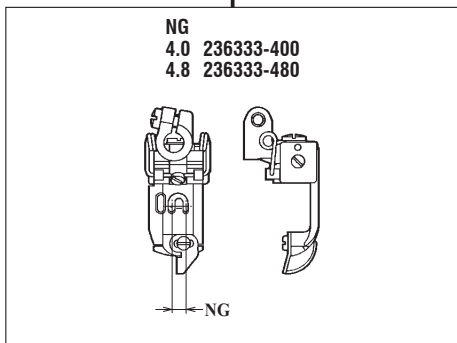
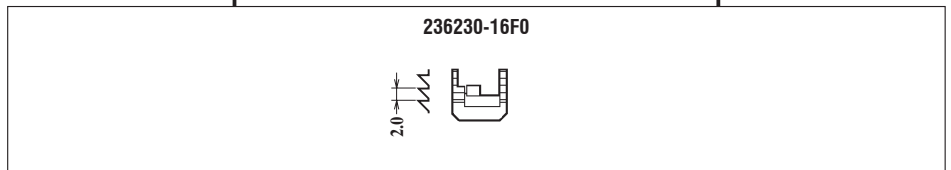
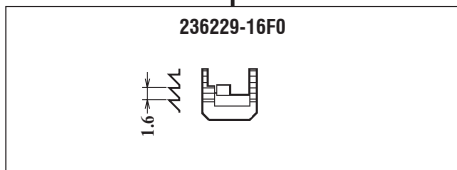
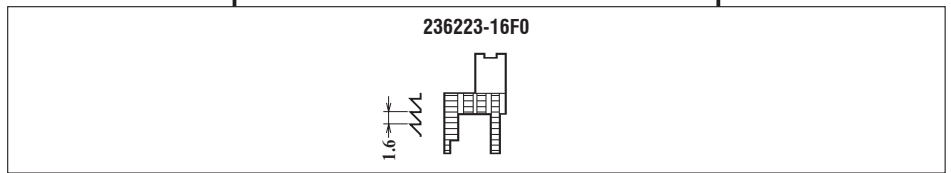
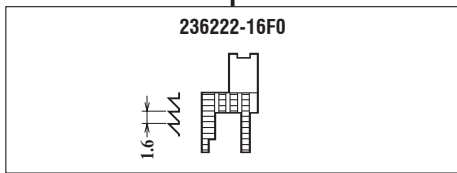
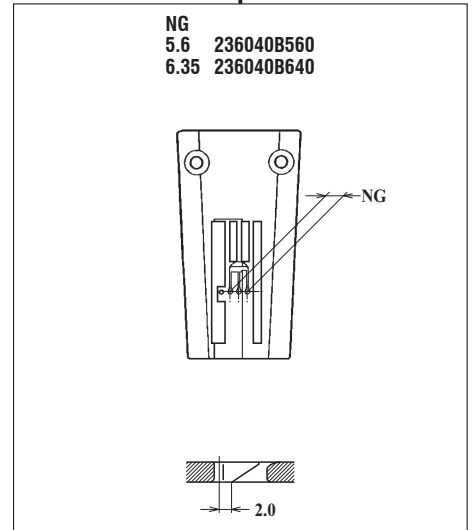
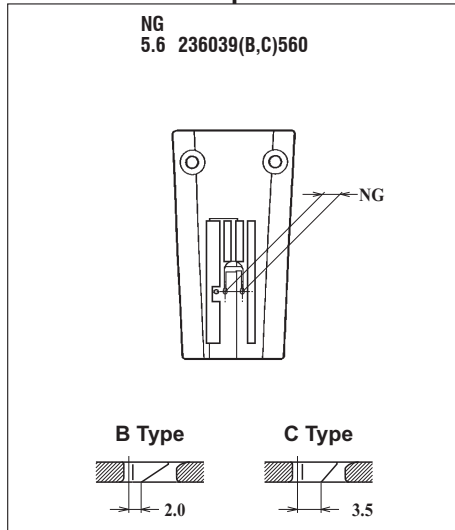
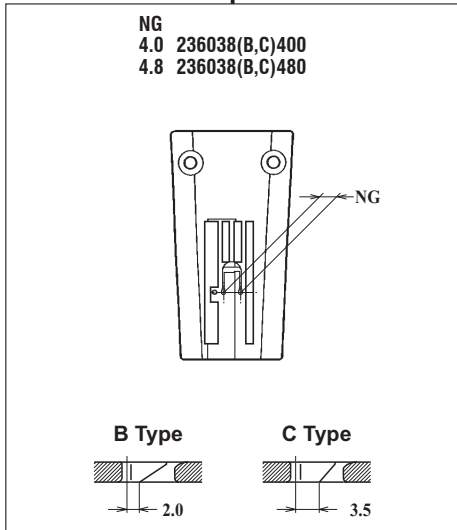
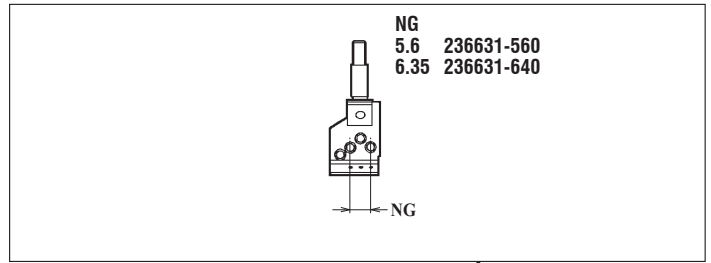
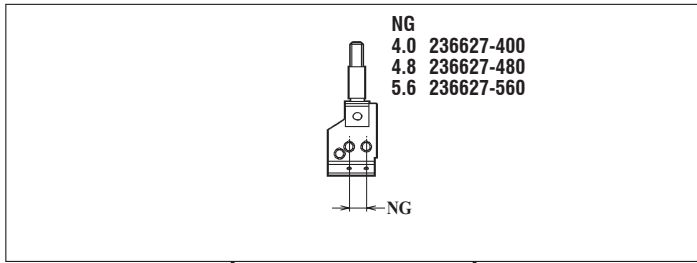

FW603GB,GC×240,248
 カバーリング用片倒し縫い (薄生地)
 COVERING FOR FOLDING OVER
 OVERLOCK SEAMS
 (LIGHT WEIGHT FABRIC)

FW603GB,GC×256
 カバーリング用片倒し縫い (薄生地)
 COVERING FOR FOLDING OVER
 OVERLOCK SEAMS
 (LIGHT WEIGHT FABRIC)

FW603GB×356,364
 カバーリング用片倒し縫い (薄生地)
 COVERING FOR FOLDING OVER
 OVERLOCK SEAMS
 (LIGHT WEIGHT FABRIC)

機種 MACHINE	針板 NEEDLE PLATE
FW603GB	B TYPE
FW603GC	C TYPE

FW204A

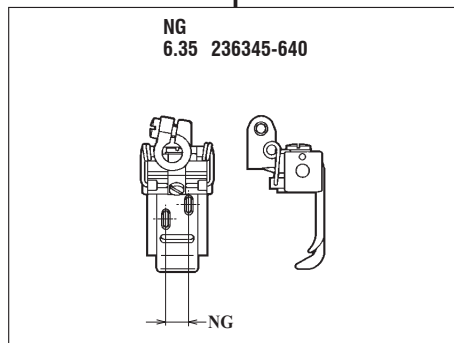
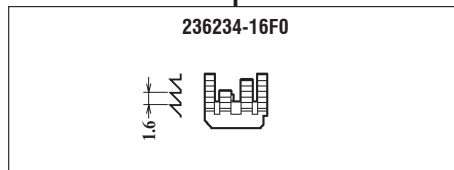
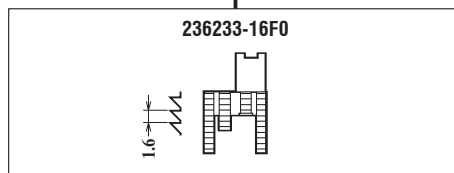
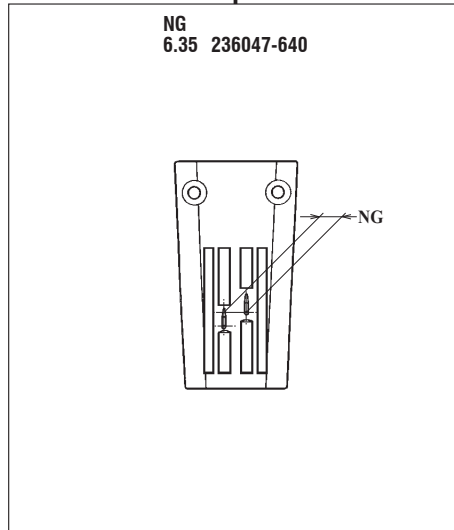
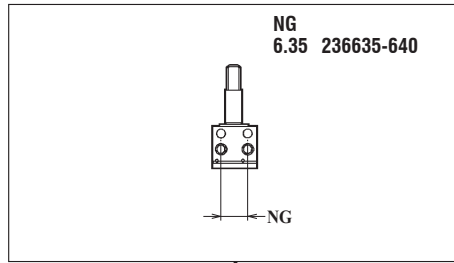

ルーパー(左) LOOPER(LEFT)
2365050



ルーパー(右) LOOPER(RIGHT)
236501B0



針受(後) NEEDLE GUARD(REAR)
2366360



FW204A × 264
テープ付け用 (中厚生地)
ATTACHING TAPE
(MEDIUM WEIGHT FABRIC)

FW403HC,JC/UT

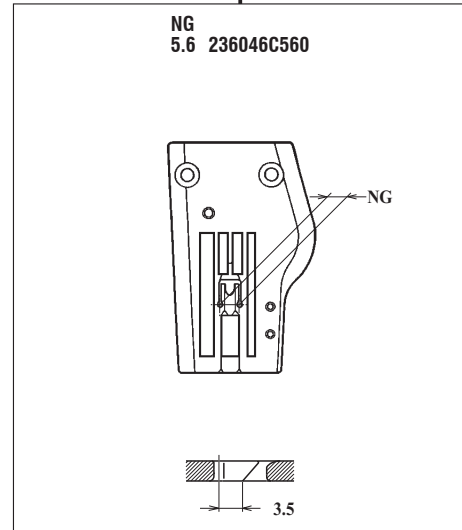
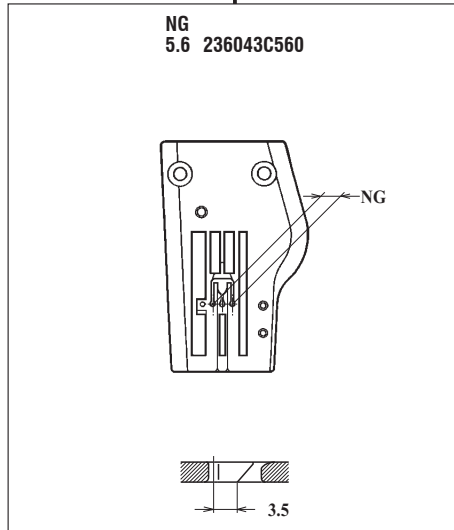
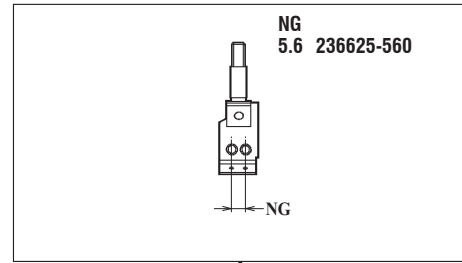
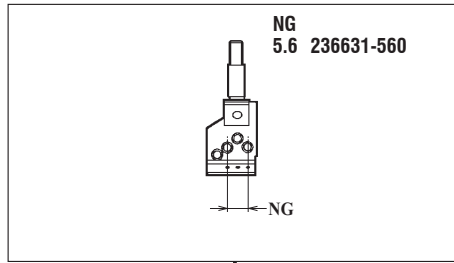

FW403,603/UT Series 共通部品 COMMON PARTS

ルーパー LOOPER
236501A0

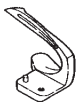

ルーパー補助器 LOOPER GUARD
2366240



針受(後) NEEDLE GUARD(REAR)
2366280



スプレッター SPREADER
207936A0
FW403HC,JC/UTは除く
Except FW403HC,JC/UT

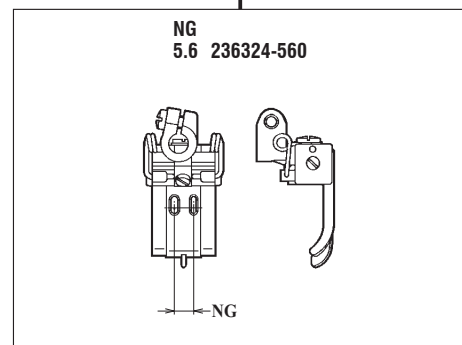
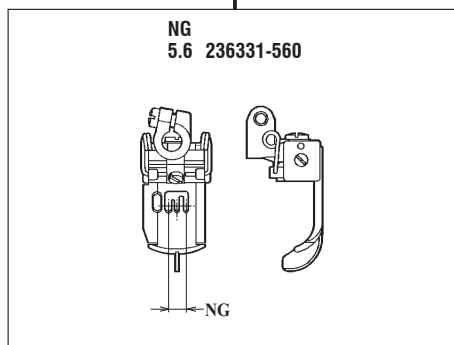
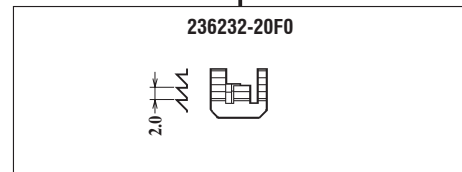
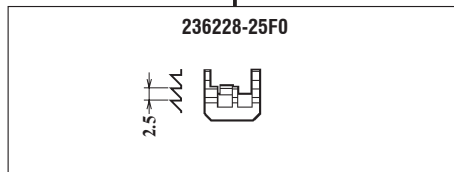
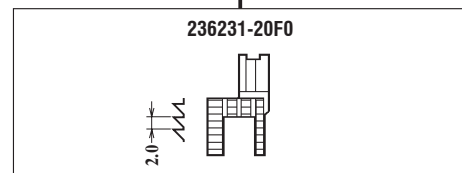
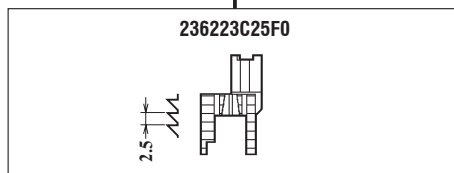
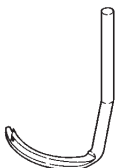

FW403HC×356/UT

カバーリング用つぶし縫い (厚生地)
COVERING FOR FLATTENING
OUT OVERLOCK SEAMS
(HEAVY WEIGHT FABRIC)

FW403JC×256/UT

カバーリング用片倒し縫い (厚生地)
COVERING FOR FOLDING
OVER OVERLOCK SEAMS
(HEAVY WEIGHT FABRIC)

FW603FB/UT

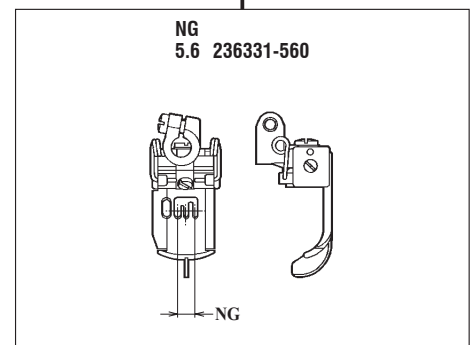
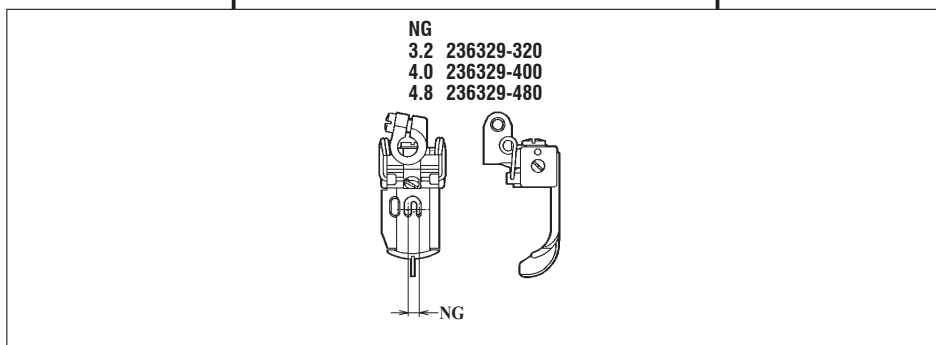
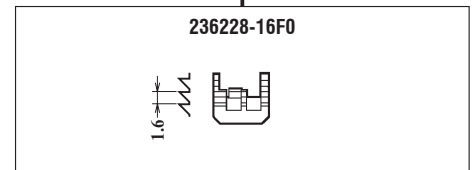
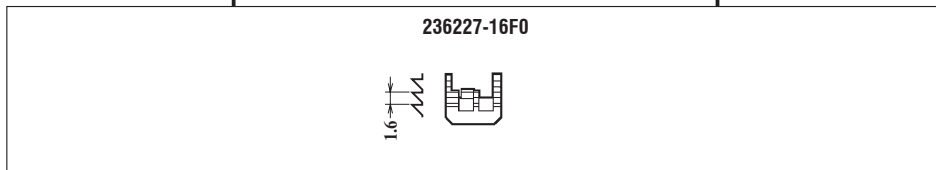
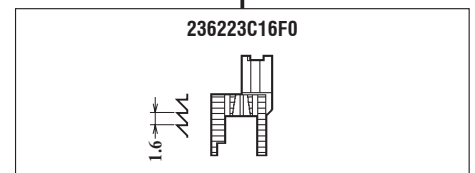
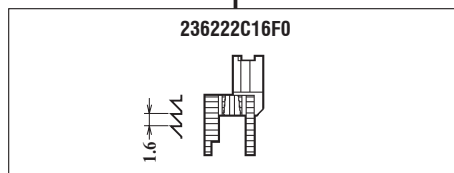
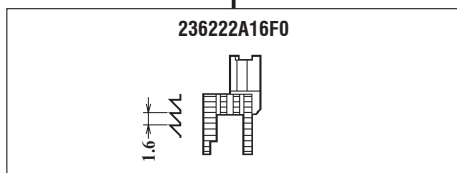
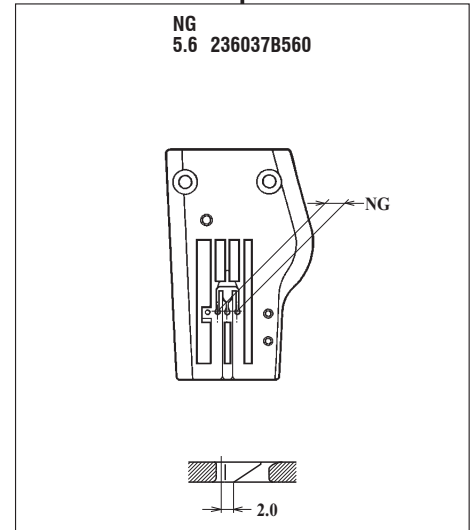
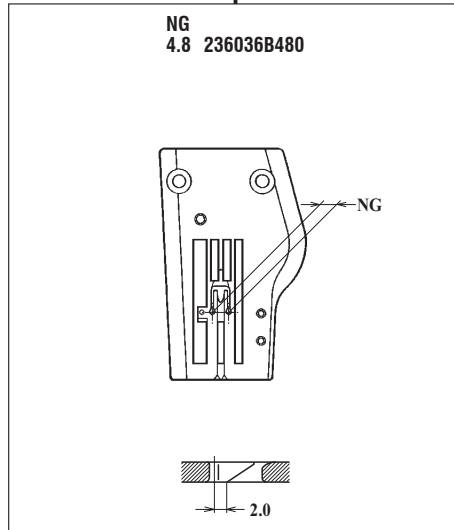
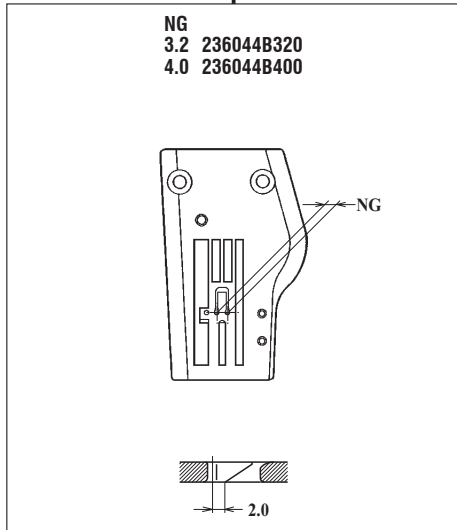
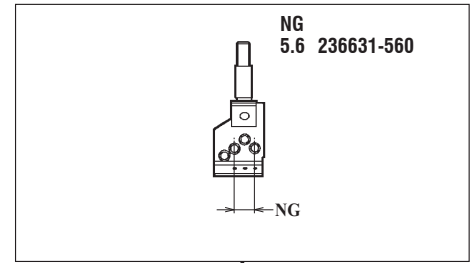
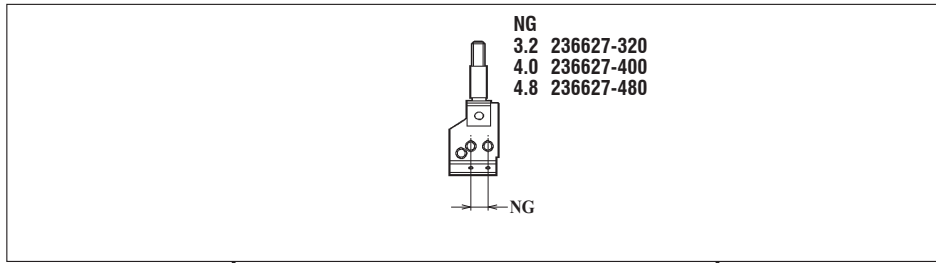

FW603FB × 232,240/UT

カバーリング用つづし縫い (厚生地)
COVERING FOR FLATTENING
OUT OVERLOCK SEAMS
(HEAVY WEIGHT FABRIC)

FW603FB × 248/UT

カバーリング用つづし縫い (厚生地)
COVERING FOR FLATTENING
OUT OVERLOCK SEAMS
(HEAVY WEIGHT FABRIC)

FW603FB × 356/UT

カバーリング用つづし縫い (厚生地)
COVERING FOR FLATTENING
OUT OVERLOCK SEAMS
(HEAVY WEIGHT FABRIC)

FW603GB/UT

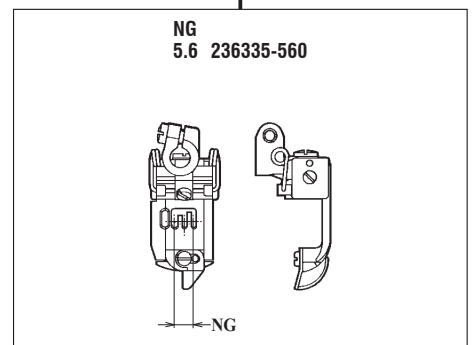
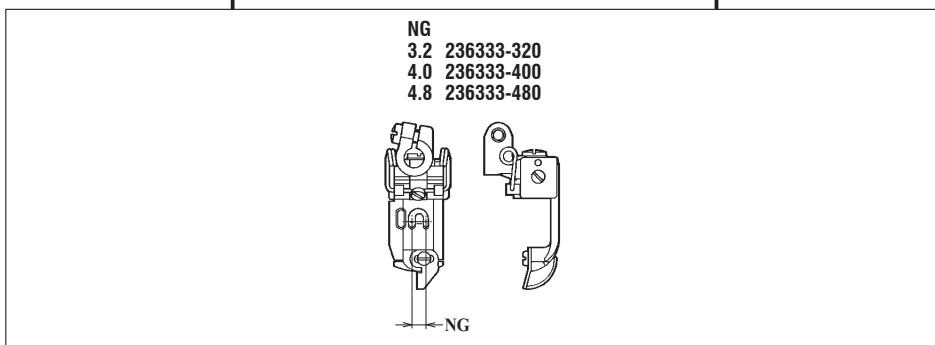
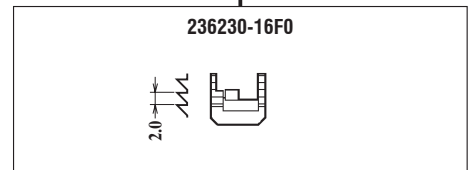
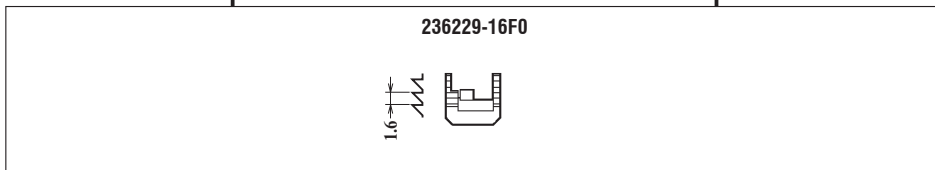
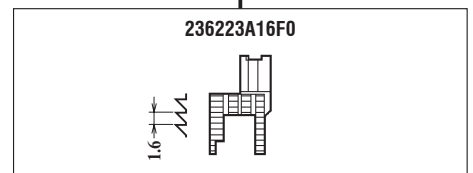
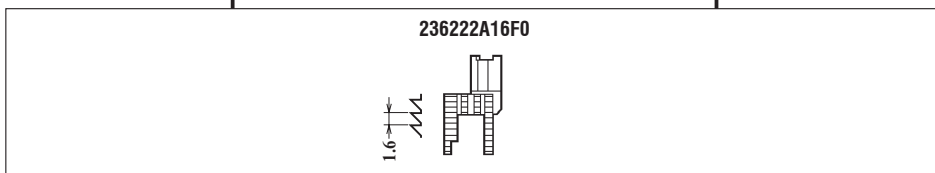
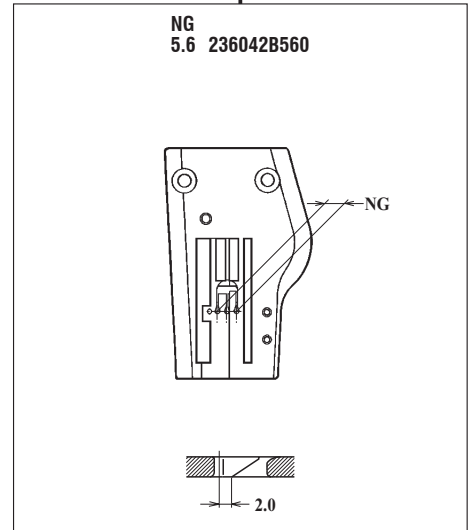
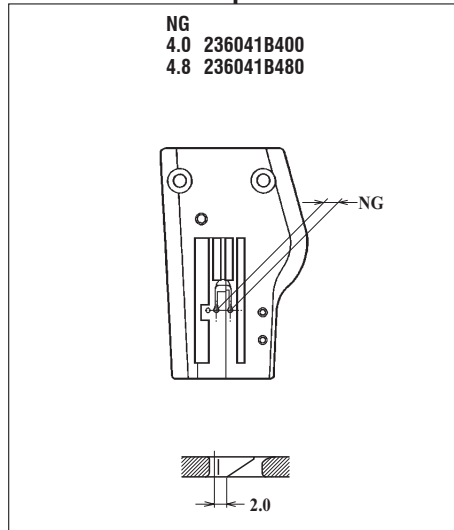
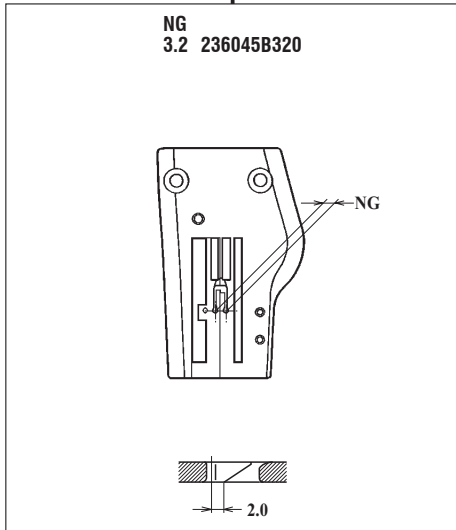
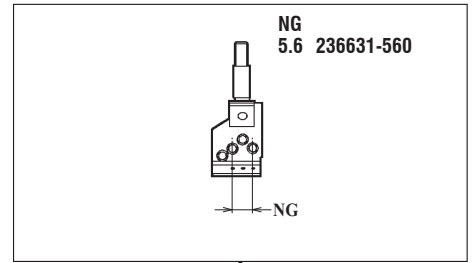
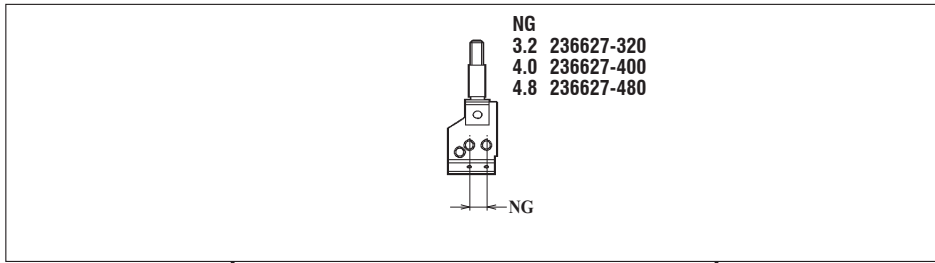

FW603GB×232/UT

カバーリング用片倒し縫い (薄生地)
COVERING FOR FOLDING
OVER OVERLOCK SEAMS
(LIGHT WEIGHT FABRIC)

FW603GB×240,248/UT

カバーリング用片倒し縫い (薄生地)
COVERING FOR FOLDING
OVER OVERLOCK SEAMS
(LIGHT WEIGHT FABRIC)

FW603GB×356/UT

カバーリング用片倒し縫い (薄生地)
COVERING FOR FOLDING
OVER OVERLOCK SEAMS
(LIGHT WEIGHT FABRIC)